

General Description

The MAX700/MAX701/MAX702 are supervisory circuits used to monitor the power supplies in microprocessor (μP) and digital systems. The $\overline{\text{RESET}}$ /RESET outputs of the MAX700/MAX701/MAX702 are guaranteed to be in the correct state for V_{CC} voltages down to +1V (Figure 4). They provide excellent circuit reliability and low cost by eliminating external components and adjustments when used with +5V-powered circuits.

The MAX702 is the simplest part in the family. When V_{CC} falls to 4.65V, $\overline{\text{RESET}}$ goes low. The MAX702 also provides a debounced manual-reset input. The MAX701 performs the same functions but has both $\overline{\text{RESET}}$ and RESET outputs. Their primary function is to provide a system reset. Accordingly, an active reset signal is supplied for low supply voltages and for at least 200ms after the supply voltage reaches its operating value.

In addition to the features of the MAX701 and MAX702, the MAX700 provides preset or adjustable-voltage detection so thresholds other than 4.65V can be selected, and adjustable hysteresis. All parts are supplied in 8-pin PDIP and narrow-SO packages in commercial and extended temperature ranges.

Applications

- Computers
- Controllers
- Intelligent Instruments
- Critical μP Power Monitoring

Features

- Min 200ms $\overline{\text{RESET}}$ Pulse on Power-Up, Power-Down, and During Low-Voltage Conditions
- Reset Threshold Factory Trimmed for +5V Systems
- No External Components or Adjustments with +5V-Powered Circuits
- Debounced Manual-Reset Input
- Preset or Adjustable-Voltage Detection (MAX700)
- Adjustable Hysteresis (MAX700)
- 8-Pin PDIP and Narrow-SO Packages

Ordering Information

PART*	TEMP RANGE	PIN-PACKAGE
MAX700C/D	0°C to +70°C	Dice
MAX700CPA	0°C to +70°C	8 PDIP
MAX700CSA	0°C to +70°C	8 Narrow SO
MAX700EPA	-40°C to +85°C	8 PDIP
MAX700ESA	-40°C to +85°C	8 Narrow SO
MAX701C/D	0°C to +70°C	Dice
MAX701CPA	0°C to +70°C	8 PDIP
MAX701CSA	0°C to +70°C	8 Narrow SO
MAX701EPA	-40°C to +85°C	8 PDIP
MAX701ESA	-40°C to +85°C	8 Narrow SO
MAX702C/D	0°C to +70°C	Dice
MAX702CPA	0°C to +70°C	8 PDIP
MAX702CSA	0°C to +70°C	8 Narrow SO
MAX702EPA	-40°C to +85°C	8 PDIP
MAX702ESA	-40°C to +85°C	8 Narrow SO

*Devices in PDIP and SO packages are available in both leaded and lead(Pb)-free packaging. Specify lead free by adding the + symbol at the end of the part number when ordering.

Pin Configurations

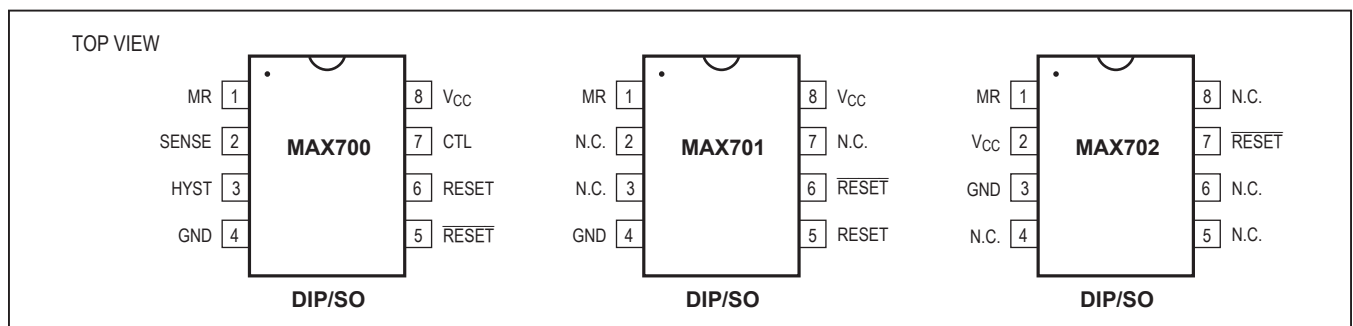

Absolute Maximum Ratings

V _{CC}	-0.3V to +15.5V	Rate of Rise, V _{CC}	100V/μs
Voltage (with respect to GND) at RESET, RESET, HYST, CTL, SENSE	-0.3V to V _{CC}	Power Dissipation, Any Package	380mW
Operating Temperature Range		Storage Temperature Range	-55°C to +150°C
C Suffix	0°C to +70°C	Lead Temperature (soldering, 10s)	+300°C
E Suffix	-40°C to +85°C		

Stresses beyond those listed under "Absolute Maximum Ratings" may cause permanent damage to the device. These are stress ratings only, and functional operation of the device at these or any other conditions beyond those indicated in the operational sections of the specifications is not implied. Exposure to absolute maximum rating conditions for extended periods may affect device reliability.

Electrical Characteristics

(V_{CC} = +5V, CTL = GND on MAX700, T_A = +25°C, unless otherwise noted.)

PARAMETER	CONDITIONS	MIN	TYP	MAX	UNITS	
V _{CC} Monitor Voltage Range (MAX700 Only)	T _A = T _{MIN} to T _{MAX} , CTL = V _{CC}	3		15	V	
Min V _{CC} for Valid Reset Output, Declining Supply	T _A = T _{MIN} to T _{MAX} , V _{RESET} ≤ 0.4V when sinking 1mA	1.5	1		V	
Supply Current			100	200	μA	
Reset Threshold	T _A = T _{MIN} to T _{MAX}	Power-up	4.50	4.65	4.75	V
		Power-down	4.50	4.62	4.75	
Internal Hysteresis	HYST not connected		30		mV	
Reset Output Pulse Width		200	350	500	ms	
RESET Fall Time	MAX700/MAX701 only, C _{LOAD} = 100pF		200		ns	
V _{CC} Pulse Duration Guaranteeing	5V to 4V V _{CC} pulse	No reset		10	1	μs
		Reset	100	10		
MR Input Threshold			0.7		V	
MR Pullup Current			-5	-30	μA	
MAX700						
RESET Output Low	I _{SINK} = 3.2mA, V _{CC} = 5V			0.4	V	
	I _{SINK} = 1.6mA, V _{CC} = 3V			0.4		
RESET Output High	I _{SOURCE} = 3.2mA, V _{CC} = 4.25V	V _{CC} - 0.4			V	
	I _{SOURCE} = 1.6mA, V _{CC} = 3V	V _{CC} - 0.4				
	I _{SOURCE} = 0.5mA, V _{CC} = 1.5V	V _{CC} - 0.4				
RESET Output Low	I _{SINK} = 16mA, V _{CC} = 4.25V			0.4	V	
	I _{SINK} = 1.6mA, V _{CC} = 3V			0.4		
	I _{SINK} = 0.4mA, V _{CC} = 1.5V			0.4		
RESET Output High	I _{SOURCE} = 3.2mA, V _{CC} = 5V	V _{CC} - 0.4			V	
	I _{SOURCE} = 1.6mA, V _{CC} = 3V	V _{CC} - 0.4				

Electrical Characteristics (continued)(V_{CC} = +5V, CTL = GND on MAX700, T_A = +25°C, unless otherwise noted.)

PARAMETER	CONDITIONS	MIN	TYP	MAX	UNITS
MAX701					
RESET Output Low	I _{SINK} = 16mA, V _{CC} = 5V			0.4	V
RESET Output High	I _{SOURCE} = 3.2mA, V _{CC} = 4.25V	V _{CC} - 0.4			V
	I _{SOURCE} = 1.6mA, V _{CC} = 3V	V _{CC} - 0.4			
	I _{SOURCE} = 0.5mA, V _{CC} = 1.5V	V _{CC} - 0.4			
RESE \bar{T} Output Low	I _{SINK} = 3.2mA, V _{CC} = 4.25V			0.4	V
	I _{SINK} = 1.6mA, V _{CC} = 3V			0.4	
	I _{SINK} = 0.4mA, V _{CC} = 1.5V			0.4	
RESE \bar{T} Output High	I _{SOURCE} = 3.2mA, V _{CC} = 5V	V _{CC} - 0.4			V
MAX702					
RESE \bar{T} Output Low	I _{SINK} = 3.2mA, V _{CC} = 4.25V			0.4	V
	I _{SINK} = 1.6mA, V _{CC} = 3V			0.4	
	I _{SINK} = 0.4mA, V _{CC} = 1.5V			0.4	
RESE \bar{T} Output High	I _{SOURCE} = 3.2mA, V _{CC} = 5V	V _{CC} - 0.4			V
MAX700 ONLY (CTL = V_{CC}, unless otherwise noted)					
SENSE Input Threshold	T _A = T _{MIN} to T _{MAX}	1.25	1.29	1.35	V
SENSE Input Current			0.1		nA
HYST Input On-Resistance			0.5		kΩ
CTL Input Threshold			2		V
CTL Pulldown Current			30	100	μA

Pin Description

PIN			NAME	FUNCTION
MAX700	MAX701	MAX702		
1	1	1	MR	Input for Manual Pushbutton Reset. Has internal 5 μ A pullup. Low input activates the RESET/RESET outputs.
2	—	—	SENSE	The voltage-sense input when CTL = V _{CC} . Its threshold is 1.29V. SENSE always remains connected to the internal comparator. So, when V _{CC} is being monitored internally (CTL = GND), SENSE should be left open circuit.
3	—	—	HYST	Normally NOT used when voltage is monitored through V _{CC} (CTL = GND). When monitoring through SENSE (CTL = V _{CC}), HYST allows hysteresis to be added, reducing noise and spurious reset activity (Figure 3). HYST turns on 5 μ s before the RESET/RESET outputs are activated, and its on-resistance to GND is typically 1k Ω .
4	4	3	GND	Ground
5	6	7	RESET	Goes low when V _{CC} falls below 4.65V, or when CTL = V _{CC} on the MAX700 goes low when SENSE falls below 1.29V.
6	5	—	RESET	Inverted Version of RESET
7	—	—	CTL	When CTL = GND, V _{CC} is monitored by the reset circuit. When CTL = V _{CC} , V _{CC} is ignored and SENSE is monitored, allowing the threshold to be set with external resistors.
8	8	2	V _{CC}	Chip Power and +5V Sensing Input (When CTL = GND on MAX700)
—	2, 3, 7	4, 5, 6, 8	N.C.	No Connection

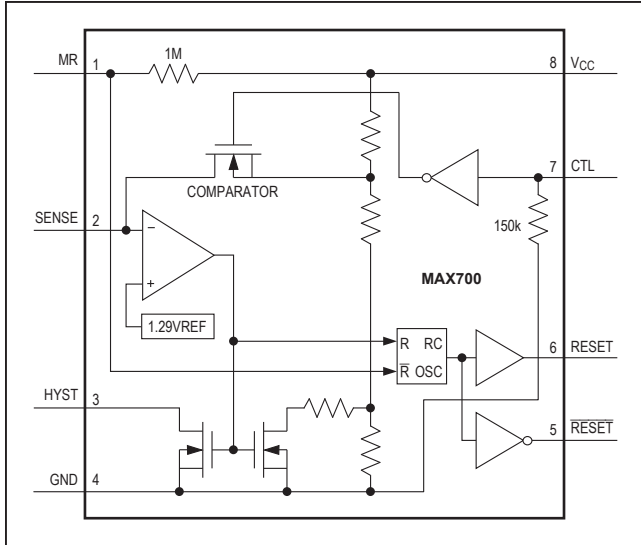

Figure 1. MAX700 Block Diagram

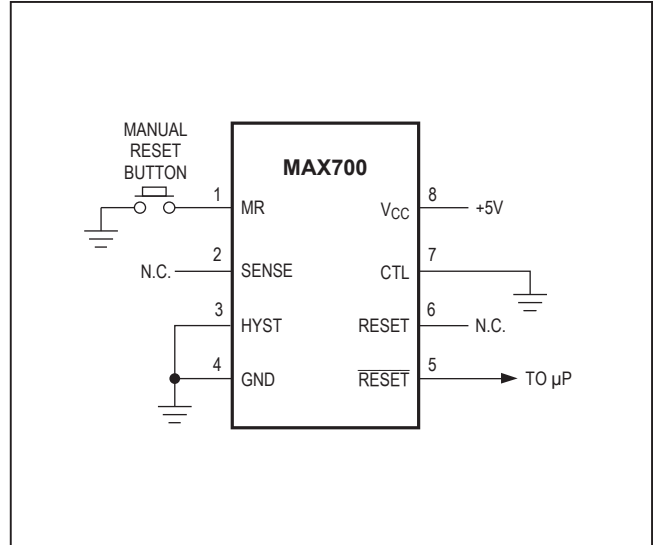

Figure 2. MAX700 Typical Connection Diagram

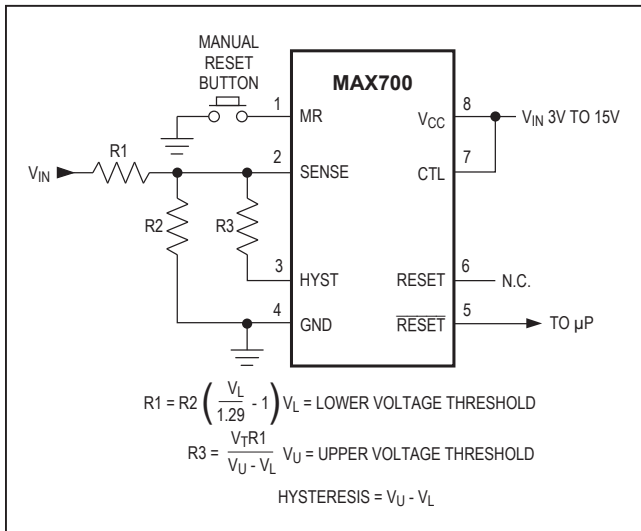

Figure 3. MAX700 Connected for External Senses and Hysteresis

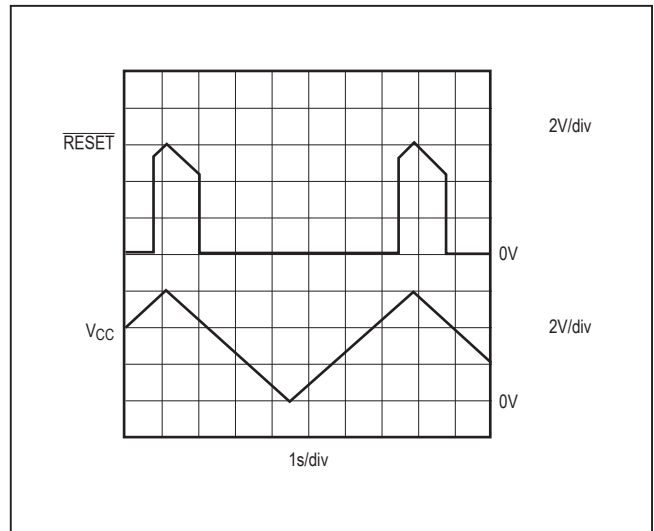

Figure 4. Typical MAX700/MAX701/MAX702 RESET Output vs. VCC

Figure 4 shows the $\overline{\text{RESET}}$ output of the MAX700/MAX701/MAX702 in the correct state for VCC voltages down to 0V. Note the effect of the built-in hysteresis on the trigger level of $\overline{\text{RESET}}$.

Package Information

For the latest package outline information and land patterns (footprints), go to www.maximintegrated.com/packages. Note that a “+”, “#”, or “-” in the package code indicates RoHS status only. Package drawings may show a different suffix character, but the drawing pertains to the package regardless of RoHS status.

PACKAGE TYPE	PACKAGE CODE	OUTLINE NO.	LAND PATTERN NO.
8 PDIP	P8+2	21-0143	—
8 Narrow SO	S8+4	21-0041	90-0096

Revision History

REVISION NUMBER	REVISION DATE	DESCRIPTION	PAGES CHANGED
0	3/90	Initial release	—
1	11/05	Added lead-free information to the <i>Ordering Information</i> table.	1
2	12/07	Updated <i>Pin Description</i> table.	4
3	5/14	No <i>IV</i> OPNs; removed automotive reference from <i>Applications</i> section	1

For pricing, delivery, and ordering information, please contact Maxim Direct at 1-888-629-4642, or visit Maxim Integrated's website at www.maximintegrated.com.

Maxim Integrated cannot assume responsibility for use of any circuitry other than circuitry entirely embodied in a Maxim Integrated product. No circuit patent licenses are implied. Maxim Integrated reserves the right to change the circuitry and specifications without notice at any time. The parametric values (min and max limits) shown in the Electrical Characteristics table are guaranteed. Other parametric values quoted in this data sheet are provided for guidance.