

Low Voltage Precision Adjustable Shunt Regulator

TLV431, NCV431, SCV431

The TLV431A, B and C series are precision low voltage shunt regulators that are programmable over a wide voltage range of 1.24 V to 16 V. The TLV431A series features a guaranteed reference accuracy of $\pm 1.0\%$ at 25 °C and $\pm 2.0\%$ over the entire industrial temperature range of -40 °C to 85 °C. The TLV431B series features higher reference accuracy of $\pm 0.5\%$ and $\pm 1.0\%$ respectively. For the TLV431C series, the accuracy is even higher. It is $\pm 0.2\%$ and $\pm 1.0\%$ respectively. These devices exhibit a sharp low current turn-on characteristic with a low dynamic impedance of 0.20 Ω over an operating current range of 100 μ A to 20 mA. This combination of features makes this series an excellent replacement for zener diodes in numerous applications circuits that require a precise reference voltage. When combined with an optocoupler, the TLV431A/B/C can be used as an error amplifier for controlling the feedback loop in isolated low output voltage (3.0 V to 3.3 V) switching power supplies. These devices are available in economical TO-92-3 and micro size TSOP-5 and SOT-23-3 packages.

Features

- Programmable Output Voltage Range of 1.24 V to 16 V
- Voltage Reference Tolerance $\pm 1.0\%$ for A Series, $\pm 0.5\%$ for B Series and $\pm 0.2\%$ for C Series
- Sharp Low Current Turn-On Characteristic
- Low Dynamic Output Impedance of 0.20 Ω from 100 μ A to 20 mA
- Wide Operating Current Range of 50 μ A to 20 mA
- Micro Miniature TSOP-5, SOT-23-3 and TO-92-3 Packages
- NCV and SCV Prefix for Automotive and Other Applications Requiring Unique Site and Control Change Requirements; AEC-Q100 Qualified and PPAP Capable
- These are Pb-Free and Halide-Free Devices

Applications

- Low Output Voltage (3.0 V to 3.3 V) Switching Power Supply Error Amplifier
- Adjustable Voltage or Current Linear and Switching Power Supplies
- Voltage Monitoring
- Current Source and Sink Circuits
- Analog and Digital Circuits Requiring Precision References
- Low Voltage Zener Diode Replacements

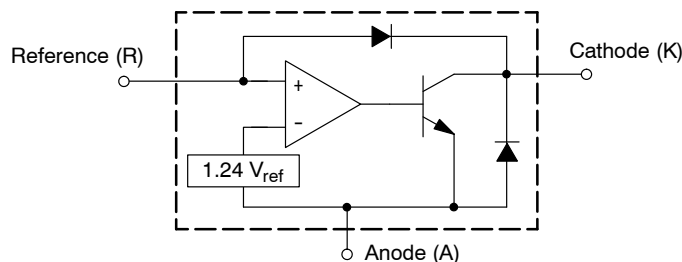
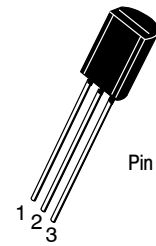
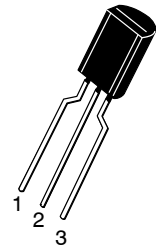

Figure 1. Representative Block Diagram



STRAIGHT LEAD
BULK PACK

TO-92
LP SUFFIX
CASE 29-10



BENT LEAD
TAPE & REEL
AMMO PACK

TO-92
LPRA, LPRE, LPRM,
LPRP SUFFIX
CASE 29-10

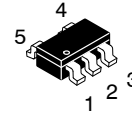

Pin 1. NC
2. NC
3. Cathode
4. Reference
5. Anode

TSOP-5
SN SUFFIX
CASE 483

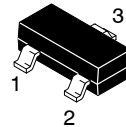

Pin 1. Reference
2. Cathode
3. Anode

SOT-23
SN1 SUFFIX
CASE 318

ORDERING INFORMATION

See detailed ordering and shipping information in the package dimensions section on page 14 of this data sheet.

NOTE: Some of the devices on this data sheet have been **DISCONTINUED**. Please refer to the table on page 14.

DEVICE MARKING INFORMATION AND PIN CONNECTIONS

See general marking information in the device marking section on page 13 of this data sheet.

TLV431, NCV431, SCV431

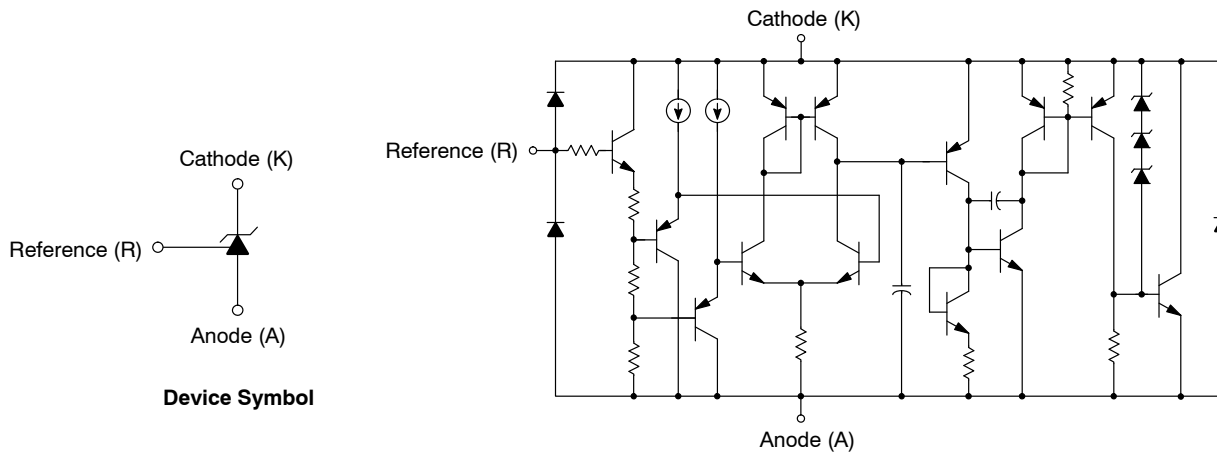

The device contains 13 active transistors.

Figure 2. Representative Device Symbol and Schematic Diagram

MAXIMUM RATINGS (Full operating ambient temperature range applies, unless otherwise noted)

Rating	Symbol	Value	Unit
Cathode to Anode Voltage	V_{KA}	18	V
Cathode Current Range, Continuous	I_K	-20 to 25	mA
Reference Input Current Range, Continuous	I_{ref}	-0.05 to 10	mA
Thermal Characteristics			$^{\circ}C/W$
LP Suffix Package, TO-92-3 Package			
Thermal Resistance, Junction-to-Ambient	$R_{\theta JA}$	178	
Thermal Resistance, Junction-to-Case	$R_{\theta JC}$	83	
SN Suffix Package, TSOP-5 Package			
Thermal Resistance, Junction-to-Ambient	$R_{\theta JA}$	226	
SN1 Suffix Package, SOT-23-3 Package			
Thermal Resistance, Junction-to-Ambient	$R_{\theta JA}$	491	
Operating Junction Temperature	T_J	150	$^{\circ}C$
Operating Ambient Temperature Range	T_A	-40 to 85 -40 to 125	$^{\circ}C$
		TLV431 NCV431, SCV431	
Storage Temperature Range	T_{stg}	-65 to 150	$^{\circ}C$

Stresses exceeding those listed in the Maximum Ratings table may damage the device. If any of these limits are exceeded, device functionality should not be assumed, damage may occur and reliability may be affected.

NOTE: This device series contains ESD protection and exceeds the following tests:

Human Body Model 2000 V per JEDEC JESD22-A114F, Machine Model Method 200 V per JEDEC JESD22-A115C,

Charged Device Method 1000 V per JEDEC JESD22-C101E. This device contains latch-up protection and exceeds ± 100 mA per JEDEC standard JESD78.

$$P_D = \frac{T_{J(max)} - T_A}{R_{\theta JA}}$$

RECOMMENDED OPERATING CONDITIONS

Condition	Symbol	Min	Max	Unit
Cathode to Anode Voltage	V_{KA}	V_{ref}	16	V
Cathode Current	I_K	0.1	20	mA

Functional operation above the stresses listed in the Recommended Operating Ranges is not implied. Extended exposure to stresses beyond the Recommended Operating Ranges limits may affect device reliability.

TLV431, NCV431, SCV431

ELECTRICAL CHARACTERISTICS (T_A = 25 °C unless otherwise noted)

Characteristic	Symbol	TLV431A			TLV431B			Unit
		Min	Typ	Max	Min	Typ	Max	
Reference Voltage (Figure 3) (V _{KA} = V _{ref} , I _K = 10 mA, T _A = 25 °C) (T _A = T _{low} to T _{high} , Note 1)	V _{ref}	1.228 1.215	1.240 –	1.252 1.265	1.234 1.228	1.240 –	1.246 1.252	V
Reference Input Voltage Deviation Over Temperature (Figure 3) (V _{KA} = V _{ref} , I _K = 10 mA, T _A = T _{low} to T _{high} , Notes 1, 2, 3)	ΔV _{ref}	–	7.2	20	–	7.2	20	mV
Ration of Reference Input Voltage Change to Cathode Voltage Change (Figure 4) (V _{KA} = V _{ref} to 16 V, I _K = 10 mA)	$\frac{\Delta V_{ref}}{\Delta V_{KA}}$	–	–0.6	–1.5	–	–0.6	–1.5	$\frac{mV}{V}$
Reference Terminal Current (Figure 4) (I _K = 10 mA, R1 = 10 kΩ, R2 = open)	I _{ref}	–	0.15	0.3	–	0.15	0.3	μA
Reference Input Current Deviation Over Temperature (Figure 4) (I _K = 10 mA, R1 = 10 kΩ, R2 = open, Notes 1, 2, 3)	ΔI _{ref}	–	0.04	0.08	–	0.04	0.08	μA
Minimum Cathode Current for Regulation (Figure 3)	I _{K(min)}	–	30	80	–	30	80	μA
Off-State Cathode Current (Figure 5) (V _{KA} = 6.0 V, V _{ref} = 0) (V _{KA} = 16 V, V _{ref} = 0)	I _{K(off)}	– –	0.01 0.012	0.04 0.05	– –	0.01 0.012	0.04 0.05	μA
Dynamic Impedance (Figure 3) (V _{KA} = V _{ref} , I _K = 0.1 mA to 20 mA, f ≤ 1.0 kHz, Note 4)	Z _{KA}	–	0.25	0.4	–	0.25	0.4	Ω

1. Ambient temperature range: T_{low} = –40 °C, T_{high} = 85 °C.
2. Guaranteed but not tested.
3. The deviation parameters ΔV_{ref} and ΔI_{ref} are defined as the difference between the maximum value and minimum value obtained over the full operating ambient temperature range that applied.

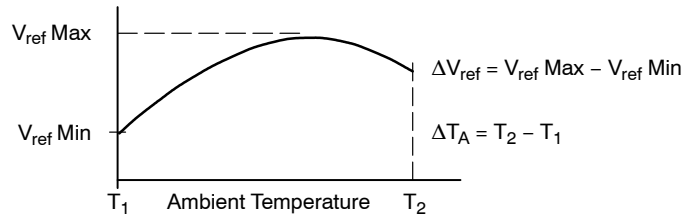

The average temperature coefficient of the reference input voltage, αV_{ref} is defined as:

$$\alpha V_{ref} \left(\frac{\text{ppm}}{^{\circ}\text{C}} \right) = \frac{\left(\frac{\Delta V_{ref}}{V_{ref} (T_A = 25^{\circ}\text{C})} \times 10^6 \right)}{\Delta T_A}$$

αV_{ref} can be positive or negative depending on whether V_{ref} Min or V_{ref} Max occurs at the lower ambient temperature, refer to Figure 8.

Example: ΔV_{ref} = 7.2 mV and the slope is positive,

$$V_{ref} @ 25^{\circ}\text{C} = 1.241 \text{ V}$$

$$\Delta T_A = 125^{\circ}\text{C}$$

$$\alpha V_{ref} \left(\frac{\text{ppm}}{^{\circ}\text{C}} \right) = \frac{0.0072 \times 10^6}{1.241 \times 125} = 46 \text{ ppm}/^{\circ}\text{C}$$

4. The dynamic impedance Z_{KA} is defined as:

$$|Z_{KA}| = \frac{\Delta V_{KA}}{\Delta I_K}$$

When the device is operating with two external resistors, R1 and R2, (refer to Figure 4) the total dynamic impedance of the circuit is given by:

$$|Z_{KA}'| = |Z_{KA}| \times \left(1 + \frac{R1}{R2} \right)$$

TLV431, NCV431, SCV431

ELECTRICAL CHARACTERISTICS ($T_A = 25\text{ }^\circ\text{C}$ unless otherwise noted)

Characteristic	Symbol	TLV431C			Unit
		Min	Typ	Max	
Reference Voltage (Figure 3) ($V_{KA} = V_{ref}$, $I_K = 10\text{ mA}$, $T_A = 25\text{ }^\circ\text{C}$) ($T_A = T_{low}$ to T_{high} , Note 5)	V_{ref}	1.237 1.228	1.240 –	1.243 1.252	V
Reference Input Voltage Deviation Over Temperature (Figure 3) ($V_{KA} = V_{ref}$, $I_K = 10\text{ mA}$, $T_A = T_{low}$ to T_{high} , Notes 5, 6, 7)	ΔV_{ref}	–	7.2	20	mV
Ration of Reference Input Voltage Change to Cathode Voltage Change (Figure 4) ($V_{KA} = V_{ref}$ to 16 V, $I_K = 10\text{ mA}$)	$\frac{\Delta V_{ref}}{\Delta V_{KA}}$	–	–0.6	–1.5	$\frac{\text{mV}}{\text{V}}$
Reference Terminal Current (Figure 4) ($I_K = 10\text{ mA}$, $R1 = 10\text{ k}\Omega$, $R2 = \text{open}$)	I_{ref}	–	0.15	0.3	μA
Reference Input Current Deviation Over Temperature (Figure 4) ($I_K = 10\text{ mA}$, $R1 = 10\text{ k}\Omega$, $R2 = \text{open}$, Notes 5, 6, 7)	ΔI_{ref}	–	0.04	0.08	μA
Minimum Cathode Current for Regulation (Figure 3)	$I_{K(\text{min})}$	–	30	80	μA
Off-State Cathode Current (Figure 5) ($V_{KA} = 6.0\text{ V}$, $V_{ref} = 0$) ($V_{KA} = 16\text{ V}$, $V_{ref} = 0$)	$I_{K(\text{off})}$	–	0.01 0.012	0.04 0.05	μA
Dynamic Impedance (Figure 3) ($V_{KA} = V_{ref}$, $I_K = 0.1\text{ mA}$ to 20 mA , $f \leq 1.0\text{ kHz}$, Note 8)	$ Z_{KA} $	–	0.25	0.4	Ω

5. Ambient temperature range: $T_{low} = -40\text{ }^\circ\text{C}$, $T_{high} = 85\text{ }^\circ\text{C}$.

6. Guaranteed but not tested.

7. The deviation parameters ΔV_{ref} and ΔI_{ref} are defined as the difference between the maximum value and minimum value obtained over the full operating ambient temperature range that applied.

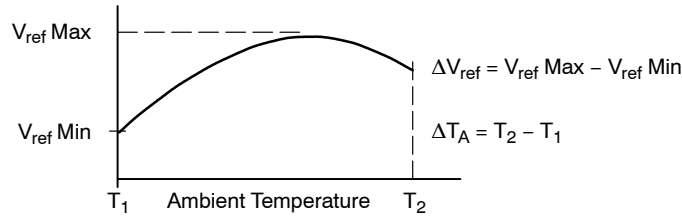

The average temperature coefficient of the reference input voltage, αV_{ref} is defined as:

$$\alpha V_{ref} \left(\frac{\text{ppm}}{^\circ\text{C}} \right) = \frac{\left(\frac{\Delta V_{ref}}{V_{ref} (T_A = 25^\circ\text{C})} \times 10^6 \right)}{\Delta T_A}$$

αV_{ref} can be positive or negative depending on whether V_{ref} Min or V_{ref} Max occurs at the lower ambient temperature, refer to Figure 8.

Example: $\Delta V_{ref} = 7.2\text{ mV}$ and the slope is positive,

$$V_{ref} @ 25\text{ }^\circ\text{C} = 1.241\text{ V}$$

$$\Delta T_A = 125\text{ }^\circ\text{C}$$

$$\alpha V_{ref} \left(\frac{\text{ppm}}{^\circ\text{C}} \right) = \frac{0.0072 \times 10^6}{1.241 \times 125} = 46\text{ ppm}/^\circ\text{C}$$

8. The dynamic impedance Z_{KA} is defined as:

$$|Z_{KA}| = \frac{\Delta V_{KA}}{\Delta I_K}$$

When the device is operating with two external resistors, $R1$ and $R2$, (refer to Figure 4) the total dynamic impedance of the circuit is given by:

$$|Z_{KA}'| = |Z_{KA}| \times \left(1 + \frac{R1}{R2} \right)$$

TLV431, NCV431, SCV431

ELECTRICAL CHARACTERISTICS ($T_A = 25\text{ }^\circ\text{C}$ unless otherwise noted. NCV prefix indicates TSOP package device. SCV prefix indicates SOT-23 package device.)

Characteristic	Symbol	NCV431A, SCV431A			Unit
		Min	Typ	Max	
Reference Voltage (Figure 3) ($V_{KA} = V_{ref}$, $I_K = 10\text{ mA}$, $T_A = 25\text{ }^\circ\text{C}$) ($T_A = -40\text{ }^\circ\text{C}$ to $85\text{ }^\circ\text{C}$) ($T_A = -40\text{ }^\circ\text{C}$ to $125\text{ }^\circ\text{C}$)	V_{ref}	1.228 1.215 1.211	1.240 – –	1.252 1.265 1.265	V
Reference Input Voltage Deviation Over Temperature (Figure 3) ($V_{KA} = V_{ref}$, $I_K = 10\text{ mA}$, $T_A = -40\text{ }^\circ\text{C}$ to $85\text{ }^\circ\text{C}$, Notes 9, 10) ($V_{KA} = V_{ref}$, $I_K = 10\text{ mA}$, $T_A = -40\text{ }^\circ\text{C}$ to $125\text{ }^\circ\text{C}$, Notes 9, 10)	ΔV_{ref}	– –	7.2 7.2	20 24	mV
Ration of Reference Input Voltage Change to Cathode Voltage Change (Figure 4) ($V_{KA} = V_{ref}$ to 16 V , $I_K = 10\text{ mA}$)	$\frac{\Delta V_{ref}}{\Delta V_{KA}}$	–	–0.6	–1.5	$\frac{\text{mV}}{\text{V}}$
Reference Terminal Current (Figure 4) ($I_K = 10\text{ mA}$, $R_1 = 10\text{ k}\Omega$, $R_2 = \text{open}$)	I_{ref}	–	0.15	0.3	μA
Reference Input Current Deviation Over Temperature (Figure 4) ($I_K = 10\text{ mA}$, $R_1 = 10\text{ k}\Omega$, $R_2 = \text{open}$, $T_A = -40\text{ }^\circ\text{C}$ to $85\text{ }^\circ\text{C}$, Notes 9, 10) ($I_K = 10\text{ mA}$, $R_1 = 10\text{ k}\Omega$, $R_2 = \text{open}$, $T_A = -40\text{ }^\circ\text{C}$ to $125\text{ }^\circ\text{C}$, Notes 9, 10)	ΔI_{ref}	– –	0.04 –	0.08 0.10	μA
Minimum Cathode Current for Regulation (Figure 3)	$I_{K(\text{min})}$	–	30	80	μA
Off-State Cathode Current (Figure 5) ($V_{KA} = 6.0\text{ V}$, $V_{ref} = 0$) ($V_{KA} = 16\text{ V}$, $V_{ref} = 0$)	$I_{K(\text{off})}$	– –	0.01 0.012	0.04 0.05	μA
Dynamic Impedance (Figure 3) ($V_{KA} = V_{ref}$, $I_K = 0.1\text{ mA}$ to 20 mA , $f \leq 1.0\text{ kHz}$, Note 11)	$ Z_{KA} $	–	0.25	0.4	Ω

9. Guaranteed but not tested.

10. The deviation parameters ΔV_{ref} and ΔI_{ref} are defined as the difference between the maximum value and minimum value obtained over the full operating ambient temperature range that applied.

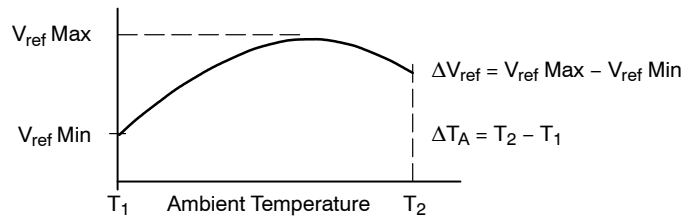

The average temperature coefficient of the reference input voltage, αV_{ref} is defined as:

$$\alpha V_{ref} \left(\frac{\text{ppm}}{^\circ\text{C}} \right) = \frac{\left(\frac{\Delta V_{ref}}{V_{ref} (T_A = 25^\circ\text{C})} \times 10^6 \right)}{\Delta T_A}$$

αV_{ref} can be positive or negative depending on whether $V_{ref} \text{ Min}$ or $V_{ref} \text{ Max}$ occurs at the lower ambient temperature, refer to Figure 8.

Example: $\Delta V_{ref} = 7.2\text{ mV}$ and the slope is positive,

$$V_{ref} @ 25\text{ }^\circ\text{C} = 1.241\text{ V}$$

$$\Delta T_A = 125\text{ }^\circ\text{C}$$

$$\alpha V_{ref} \left(\frac{\text{ppm}}{^\circ\text{C}} \right) = \frac{0.0072 \times 10^6}{125} = 46\text{ ppm}/^\circ\text{C}$$

11. The dynamic impedance Z_{KA} is defined as:

$$|Z_{KA}| = \frac{\Delta V_{KA}}{\Delta I_K}$$

When the device is operating with two external resistors, R_1 and R_2 , (refer to Figure 4) the total dynamic impedance of the circuit is given by:

$$|Z_{KA}'| = |Z_{KA}| \times \left(1 + \frac{R_1}{R_2} \right)$$

TLV431, NCV431, SCV431

ELECTRICAL CHARACTERISTICS ($T_A = 25\text{ }^\circ\text{C}$ unless otherwise noted. NCV prefix indicates TSOP package device. SCV prefix indicates SOT-23 package device.)

Characteristic	Symbol	NCV431B, SCV431B			Unit
		Min	Typ	Max	
Reference Voltage (Figure 3) ($V_{KA} = V_{ref}$, $I_K = 10\text{ mA}$, $T_A = 25\text{ }^\circ\text{C}$) ($T_A = -40\text{ }^\circ\text{C}$ to $85\text{ }^\circ\text{C}$) ($T_A = -40\text{ }^\circ\text{C}$ to $125\text{ }^\circ\text{C}$)	V_{ref}	1.234 1.228 1.224	1.240 – –	1.246 1.252 1.252	V
Reference Input Voltage Deviation Over Temperature (Figure 3) ($V_{KA} = V_{ref}$, $I_K = 10\text{ mA}$, $T_A = -40\text{ }^\circ\text{C}$ to $85\text{ }^\circ\text{C}$, Notes 9, 10) ($V_{KA} = V_{ref}$, $I_K = 10\text{ mA}$, $T_A = -40\text{ }^\circ\text{C}$ to $125\text{ }^\circ\text{C}$, Notes 9, 10)	ΔV_{ref}	– –	7.2 7.2	20 24	mV
Ration of Reference Input Voltage Change to Cathode Voltage Change (Figure 4) ($V_{KA} = V_{ref}$ to 16 V , $I_K = 10\text{ mA}$)	$\frac{\Delta V_{ref}}{\Delta V_{KA}}$	–	–0.6	–1.5	$\frac{\text{mV}}{\text{V}}$
Reference Terminal Current (Figure 4) ($I_K = 10\text{ mA}$, $R1 = 10\text{ k}\Omega$, $R2 = \text{open}$)	I_{ref}	–	0.15	0.3	μA
Reference Input Current Deviation Over Temperature (Figure 4) ($I_K = 10\text{ mA}$, $R1 = 10\text{ k}\Omega$, $R2 = \text{open}$, $T_A = -40\text{ }^\circ\text{C}$ to $85\text{ }^\circ\text{C}$, Notes 12, 13) ($I_K = 10\text{ mA}$, $R1 = 10\text{ k}\Omega$, $R2 = \text{open}$, $T_A = -40\text{ }^\circ\text{C}$ to $125\text{ }^\circ\text{C}$, Notes 12, 13)	ΔI_{ref}	– –	0.04 –	0.08 0.10	μA
Minimum Cathode Current for Regulation (Figure 3)	$I_{K(\text{min})}$	–	30	80	μA
Off-State Cathode Current (Figure 5) ($V_{KA} = 6.0\text{ V}$, $V_{ref} = 0$) ($V_{KA} = 16\text{ V}$, $V_{ref} = 0$)	$I_{K(\text{off})}$	– –	0.01 0.012	0.04 0.05	μA
Dynamic Impedance (Figure 3) ($V_{KA} = V_{ref}$, $I_K = 0.1\text{ mA}$ to 20 mA , $f \leq 1.0\text{ kHz}$, Note 14)	$ Z_{KA} $	–	0.25	0.4	Ω

12. Guaranteed but not tested.

13. The deviation parameters ΔV_{ref} and ΔI_{ref} are defined as the difference between the maximum value and minimum value obtained over the full operating ambient temperature range that applied.

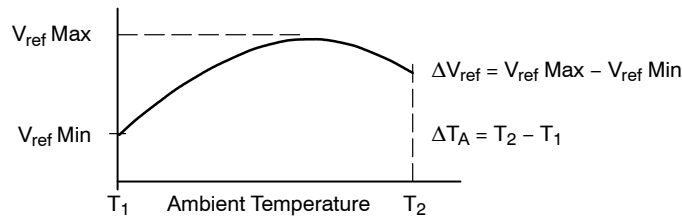

The average temperature coefficient of the reference input voltage, αV_{ref} is defined as:

$$\alpha V_{ref} \left(\frac{\text{ppm}}{^\circ\text{C}} \right) = \frac{\left(\frac{\Delta V_{ref}}{V_{ref} (T_A = 25^\circ\text{C})} \times 10^6 \right)}{\Delta T_A}$$

αV_{ref} can be positive or negative depending on whether V_{ref} Min or V_{ref} Max occurs at the lower ambient temperature, refer to Figure 8.

Example: $\Delta V_{ref} = 7.2\text{ mV}$ and the slope is positive,

$$V_{ref} @ 25\text{ }^\circ\text{C} = 1.241\text{ V}$$

$$\Delta T_A = 125\text{ }^\circ\text{C}$$

$$\alpha V_{ref} \left(\frac{\text{ppm}}{^\circ\text{C}} \right) = \frac{0.0072 \times 10^6}{1.241} = 46\text{ ppm}/^\circ\text{C}$$

14. The dynamic impedance Z_{KA} is defined as:

$$|Z_{KA}| = \frac{\Delta V_{KA}}{\Delta I_K}$$

When the device is operating with two external resistors, $R1$ and $R2$, (refer to Figure 4) the total dynamic impedance of the circuit is given by:

$$|Z_{KA}'| = |Z_{KA}| \times \left(1 + \frac{R1}{R2} \right)$$

TLV431, NCV431, SCV431

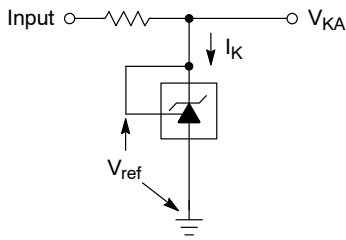

Figure 3. Test Circuit for $V_{KA} = V_{ref}$

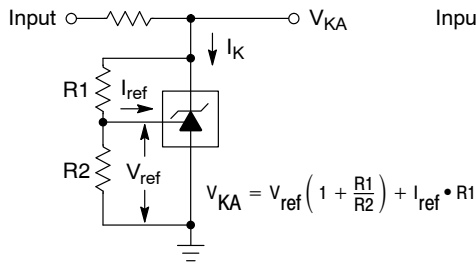

Figure 4. Test Circuit for $V_{KA} > V_{ref}$

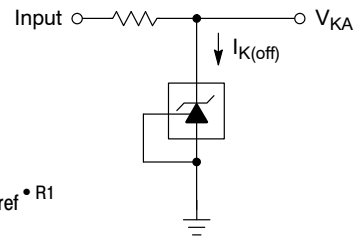

Figure 5. Test Circuit for $I_{K(off)}$

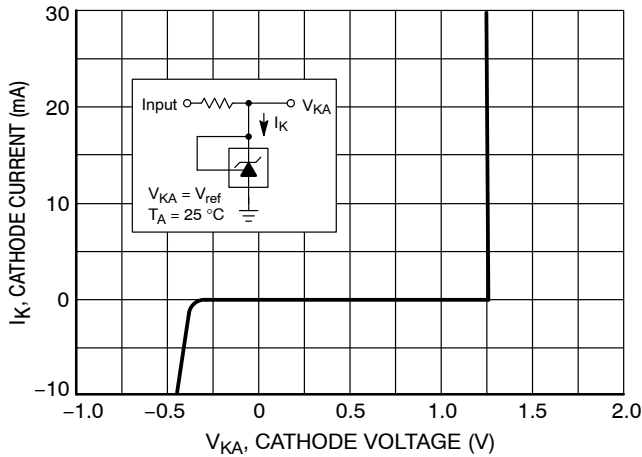

Figure 6. Cathode Current vs. Cathode Voltage

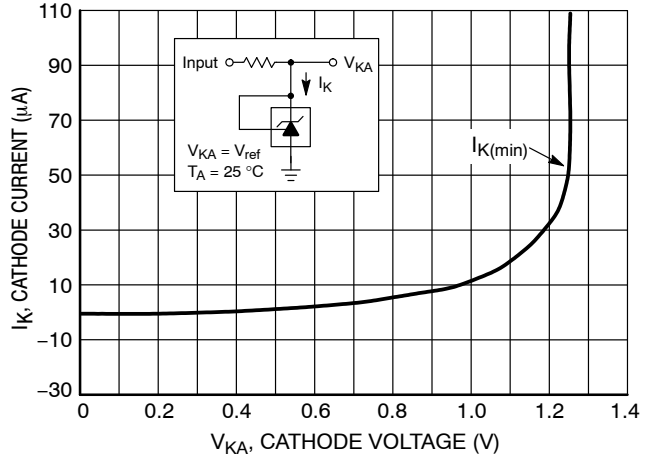

Figure 7. Cathode Current vs. Cathode Voltage

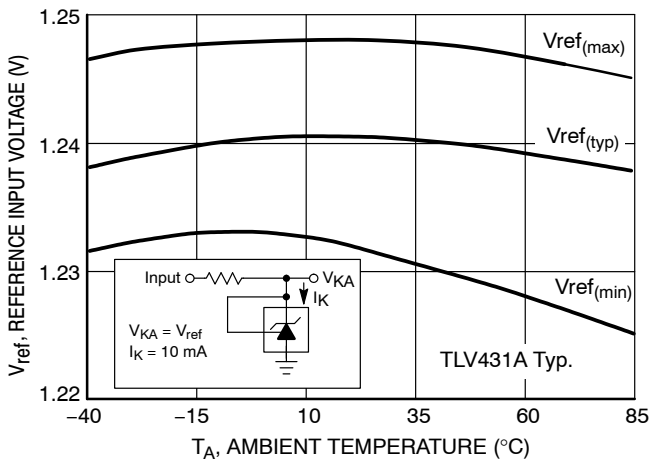

Figure 8. Reference Input Voltage versus Ambient Temperature

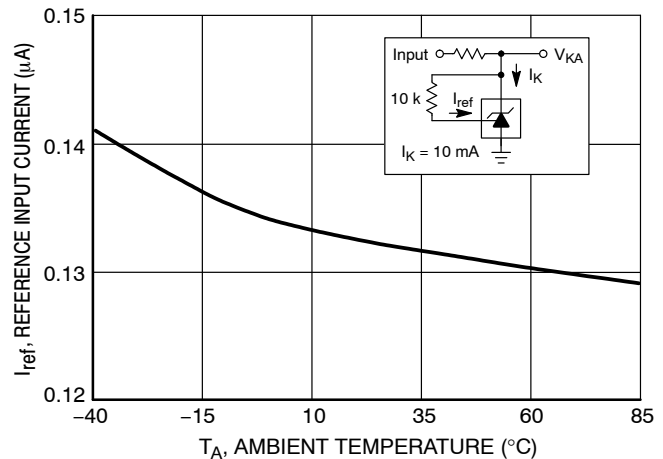

Figure 9. Reference Input Current versus Ambient Temperature

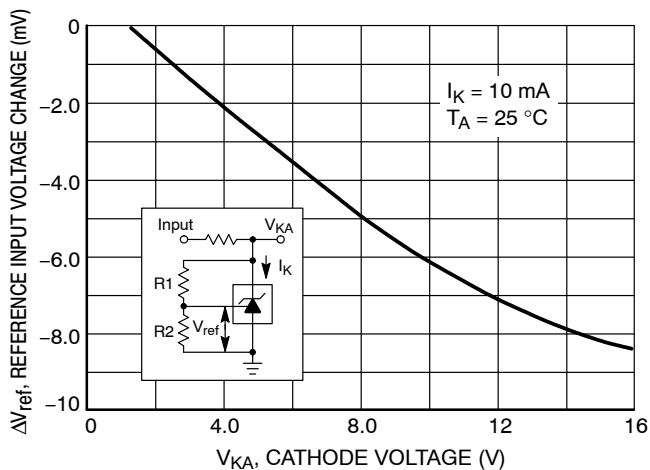

Figure 10. Reference Input Voltage Change versus Cathode Voltage

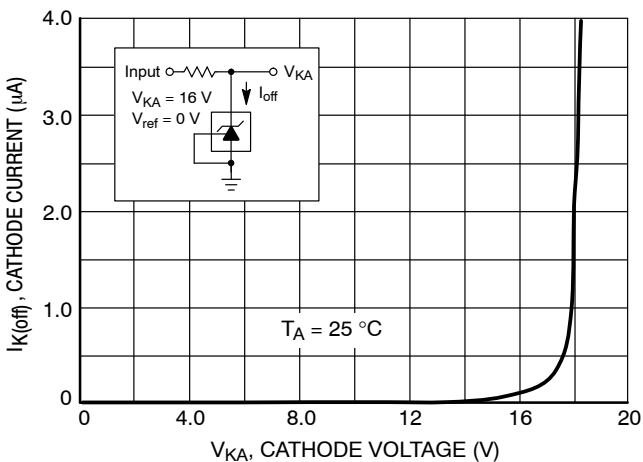

Figure 11. Off-State Cathode Current versus Cathode Voltage

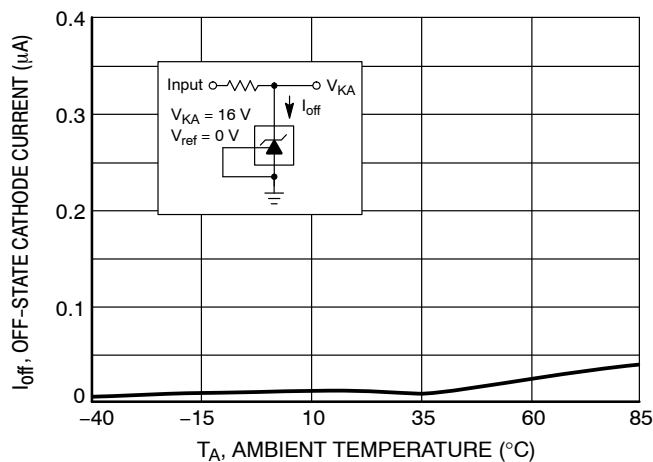

Figure 12. Off-State Cathode Current versus Ambient Temperature

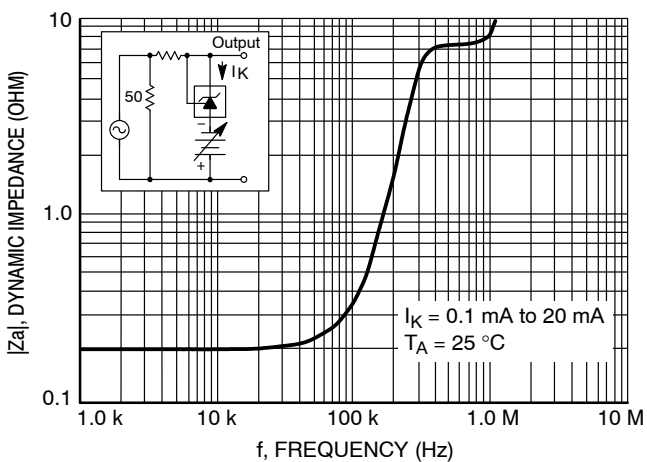

Figure 13. Dynamic Impedance versus Frequency

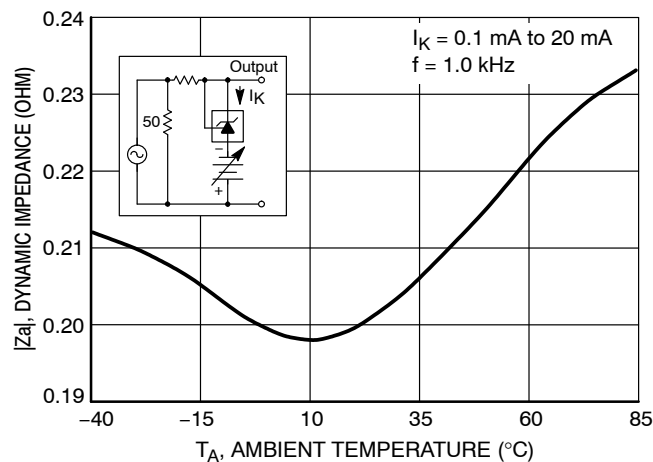

Figure 14. Dynamic Impedance versus Ambient Temperature

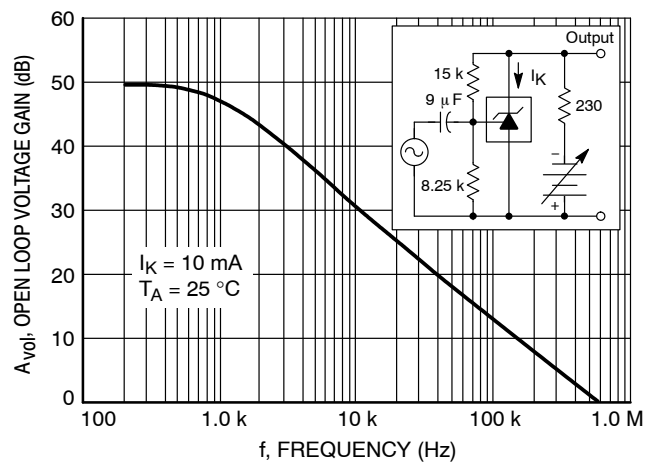

Figure 15. Open-Loop Voltage Gain versus Frequency

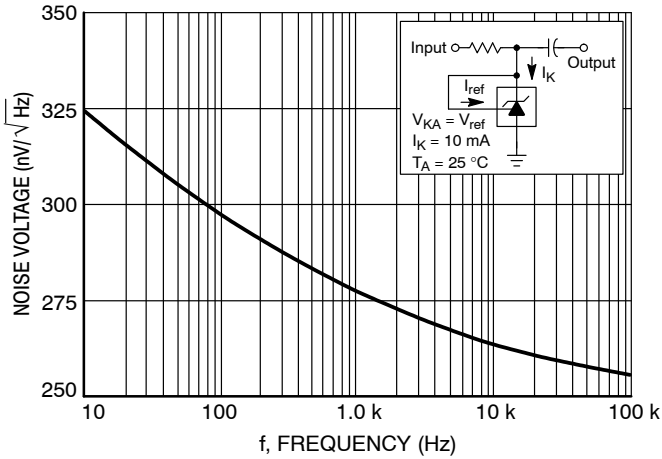

Figure 16. Spectral Noise Density

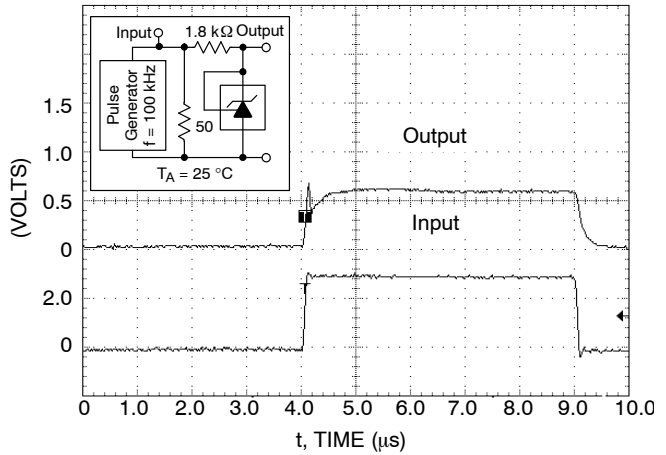

Figure 17. Pulse Response

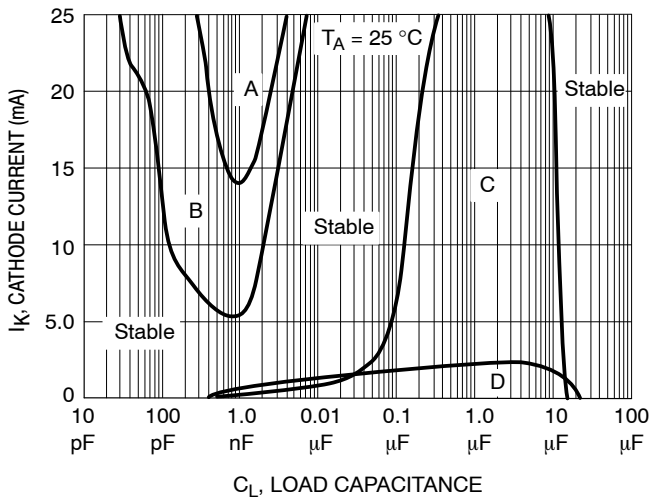
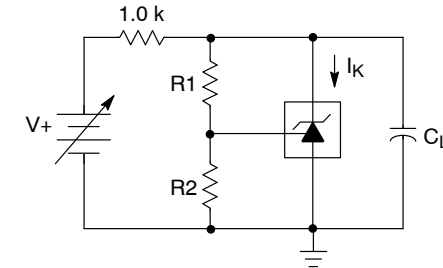

Figure 18. Stability Boundary Conditions



Unstable Regions	V _{KA} (V)	R1 (kΩ)	R2 (kΩ)
A, C	V _{ref}	0	∞
B, D	5.0	30.4	10

Figure 19. Test Circuit for Figure 18

STABILITY

Figures 18 and 19 show the stability boundaries and circuit configurations for the worst case conditions with the load capacitance mounted as close as possible to the device. The required load capacitance for stable operation can vary depending on the operating temperature and capacitor

equivalent series resistance (ESR). Ceramic or tantalum surface mount capacitors are recommended for both temperature and ESR. The application circuit stability should be verified over the anticipated operating current and temperature ranges.

TYPICAL APPLICATIONS

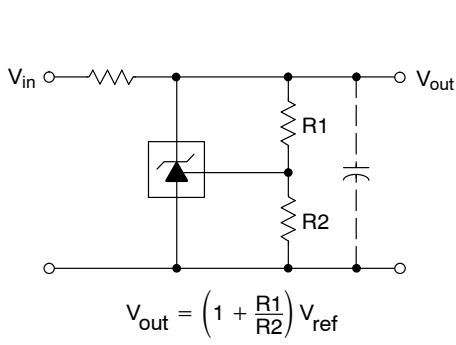

Figure 20. Shunt Regulator

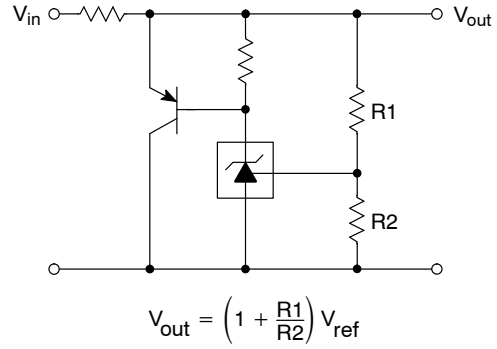

Figure 21. High Current Shunt Regulator

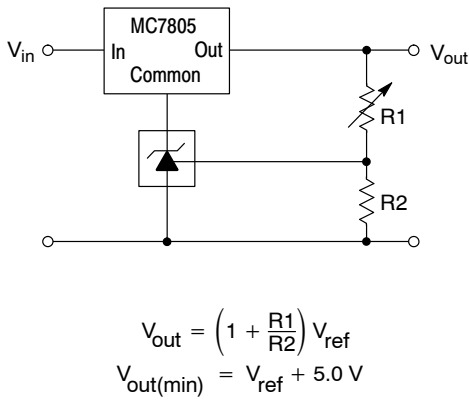

Figure 22. Output Control for a Three Terminal Fixed Regulator

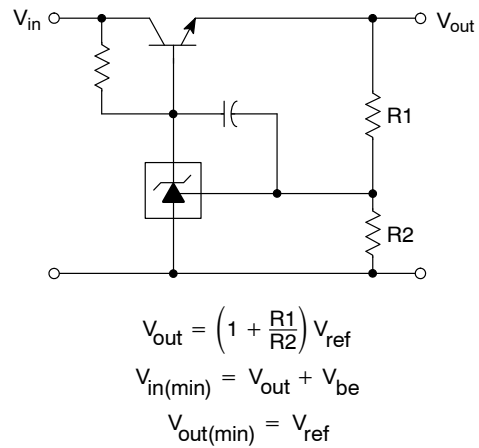

Figure 23. Series Pass Regulator

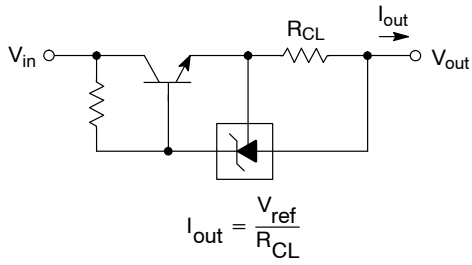

Figure 24. Constant Current Source

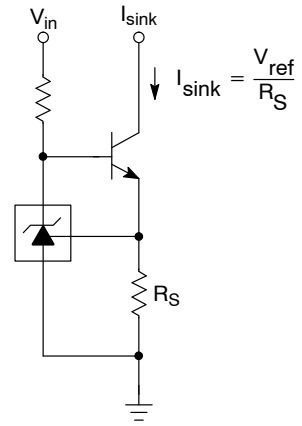

Figure 25. Constant Current Sink

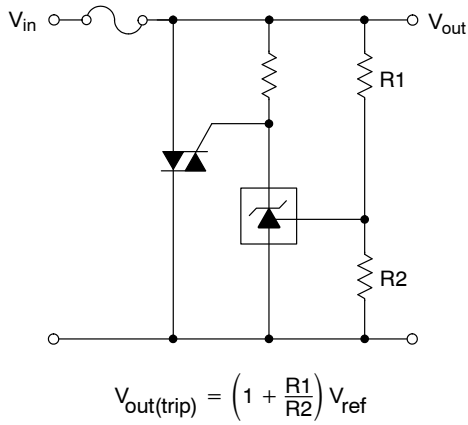

Figure 26. TRIAC Crowbar

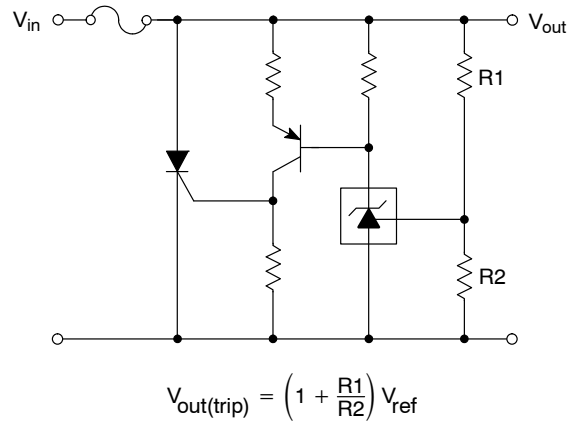
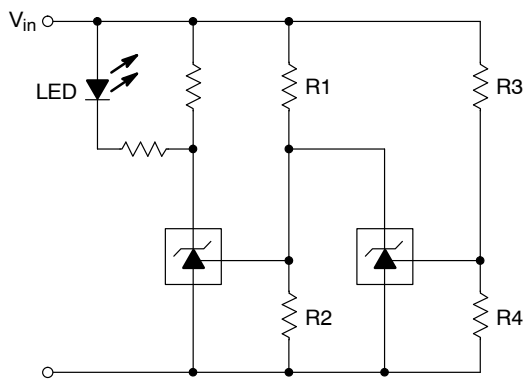

Figure 27. SCR Crowbar

TLV431, NCV431, SCV431



L.E.D. indicator is 'ON' when V_{in} is between the upper and lower limits,

$$\text{Lower limit} = \left(1 + \frac{R1}{R2}\right) V_{ref}$$

$$\text{Upper limit} = \left(1 + \frac{R3}{R4}\right) V_{ref}$$

Figure 28. Voltage Monitor

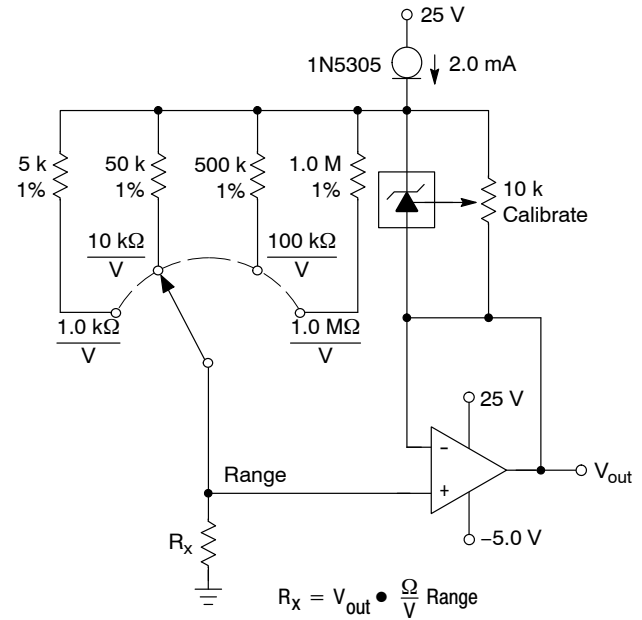

Figure 29. Linear Ohmmeter

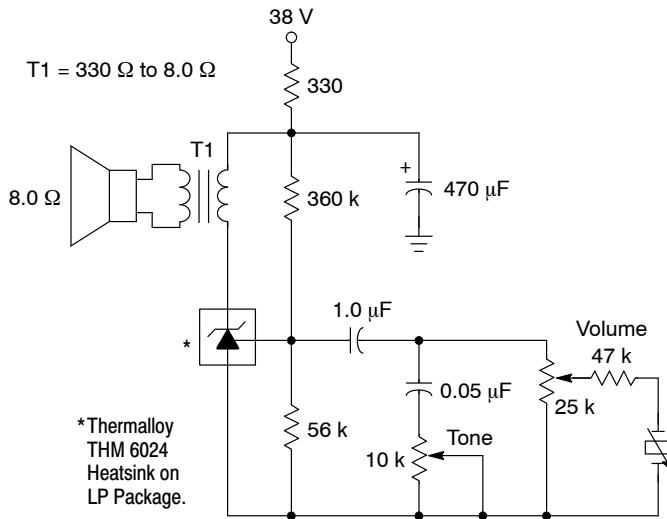

Figure 30. Simple 400 mW Phono Amplifier

TLV431, NCV431, SCV431

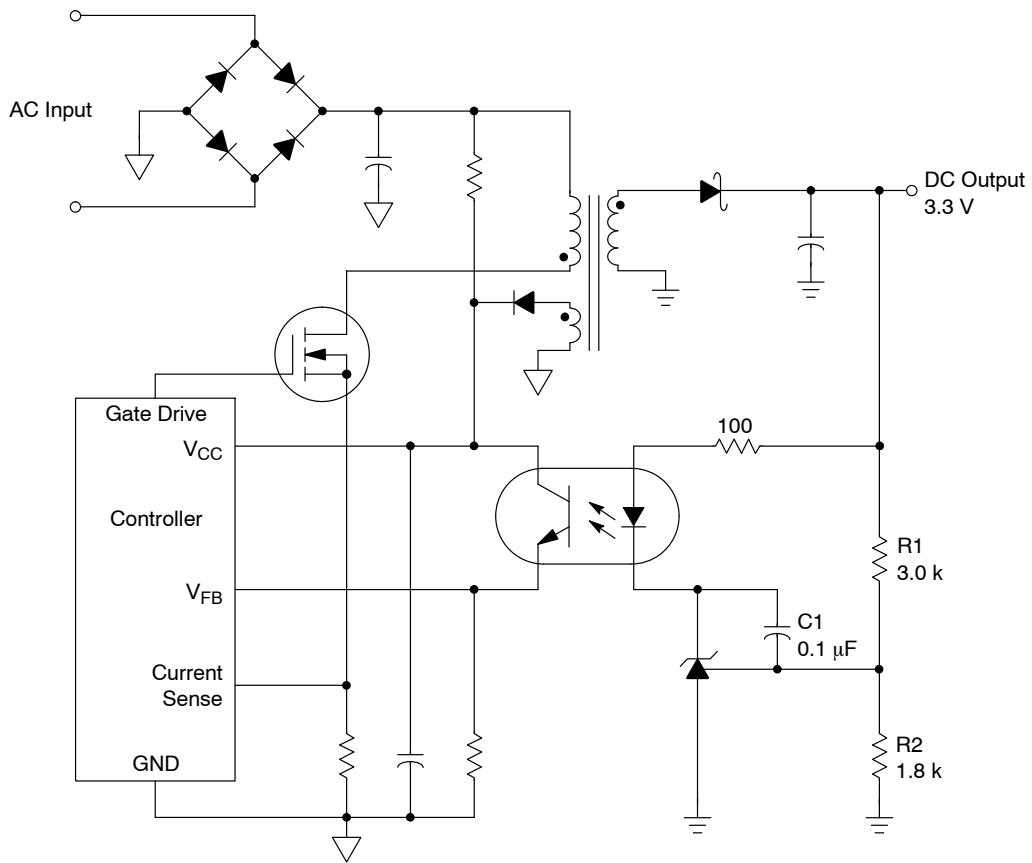
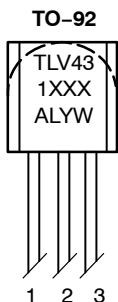

Figure 31. Isolated Output Line Powered Switching Power Supply

The above circuit shows the TLV431A/B/C as a compensated amplifier controlling the feedback loop of an isolated output line powered switching regulator. The output voltage is programmed to 3.3 V by the resistors values selected for R1 and R2. The minimum output voltage that can be programmed with this circuit is 2.64 V, and is limited by the sum of the reference voltage (1.24 V) and the forward drop of the optocoupler light emitting diode (1.4 V). Capacitor C1 provides loop compensation.

PIN CONNECTIONS AND DEVICE MARKING



1. Reference
2. Anode
3. Cathode

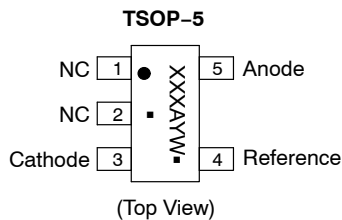

(Top View)

XXX = Specific Device Code
 A = Assembly Location
 Y = Year
 L = Wafer Lot
 W = Work Week
 ■ = Pb-Free Package
 (Note: Microdot may be in either location)

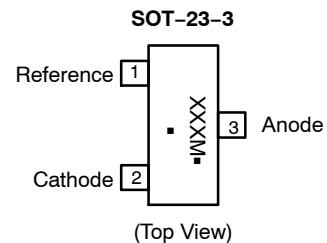

(Top View)

XXX = Specific Device Code
 M = Date Code
 ■ = Pb-Free Package
 (Note: Microdot may be in either location)

TLV431, NCV431, SCV431

ORDERING INFORMATION

Device	Device Code	Package	Shipping†
TLV431ALPRAG	ALP	TO-92-3 (Pb-Free)	2000 / Tape & Reel
TLV431ASNT1G	RAA	TSOP-5 (Pb-Free, Halide-Free)	3000 / Tape & Reel
TLV431ASN1T1G	RAF	SOT-23-3 (Pb-Free, Halide-Free)	3000 / Tape & Reel
TLV431BSNT1G	RAH	TSOP-5 (Pb-Free, Halide-Free)	3000 / Tape & Reel
TLV431BSN1T1G	RAG	SOT-23-3 (Pb-Free, Halide-Free)	3000 / Tape & Reel
TLV431CSN1T1G	AAN	SOT-23-3 (Pb-Free, Halide-Free)	3000 / Tape & Reel
SCV431ASN1T1G*	RAE	SOT-23-3 (Pb-Free, Halide-Free)	3000 / Tape & Reel
SCV431BSN1T1G*	RAC	SOT-23-3 (Pb-Free, Halide-Free)	3000 / Tape & Reel
NCV431ASNT1G*	ACH	TSOP-5 (Pb-Free, Halide-Free)	3000 / Tape & Reel
NCV431BSNT1G*	AD6	TSOP-5 (Pb-Free, Halide-Free)	3000 / Tape & Reel

DISCONTINUED (Note 15)

TLV431ALPG	ALP	TO-92-3 (Pb-Free)	6000 / Box
TLV431ALPREG	ALP	TO-92-3 (Pb-Free)	2000 / Tape & Reel
TLV431ALPRMG	ALP	TO-92-3 (Pb-Free)	2000 / Ammo Pack
TLV431ALPRPG	ALP	TO-92-3 (Pb-Free)	2000 / Ammo Pack
TLV431BLPG	BLP	TO-92-3 (Pb-Free)	6000 / Box
TLV431BLPRAG	BLP	TO-92-3 (Pb-Free)	2000 / Tape & Reel
TLV431BLPREG	BLP	TO-92-3 (Pb-Free)	2000 / Tape & Reel
TLV431BLPRMG	BLP	TO-92-3 (Pb-Free)	2000 / Ammo Pack
TLV431BLPRPG	BLP	TO-92-3 (Pb-Free)	2000 / Ammo Pack

†For information on tape and reel specifications, including part orientation and tape sizes, please refer to our Tape and Reel Packaging Specifications Brochure, BRD8011/D.

*SCV, NCV Prefix for Automotive and Other Applications Requiring Unique Site and Control Change Requirements; AEC-Q100 Qualified and PPAP Capable.

15. **DISCONTINUED:** These devices are not recommended for new design. Please contact your **onsemi** representative for information. The most current information on these devices may be available on www.onsemi.com.

TLV431, NCV431, SCV431

REVISION HISTORY

Revision	Description of Changes	Date
28	<ul style="list-style-type: none">• Rebranded the Data Sheet to onsemi format.• TLV431ALPG, TLV431ALPREG, TLV431ALPRMG, TLV431ALPRPG, TLV431BLPG, TLV431BLPRAG, TLV431BLPREG, TLV431BLPRMG, TLV431BLPRPG OPNs Marked as Discontinued.	6/5/2025

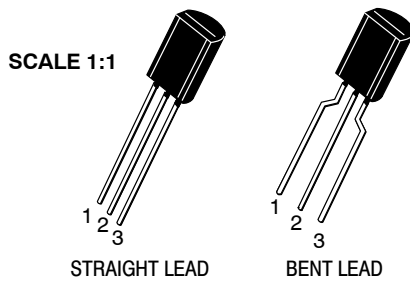

TO-92 (TO-226) 1 WATT
CASE 29-10
ISSUE D

DATE 05 MAR 2021

STRAIGHT LEAD

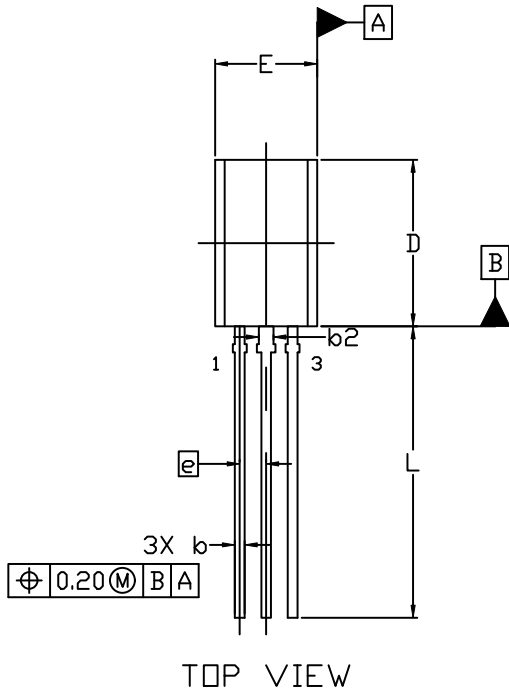
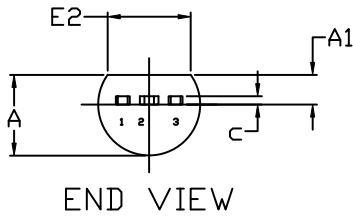

NOTES:

1. DIMENSIONING AND TOLERANCING PER ASME Y14.5M, 2009.
2. CONTROLLING DIMENSION: MILLIMETERS
3. DIMENSIONS D AND E DO NOT INCLUDE MOLD FLASH OR GATE PROTRUSIONS.
4. DIMENSION b AND b2 DOES NOT INCLUDE DAMBAR PROTRUSION. LEAD WIDTH INCLUDING PROTRUSION SHALL NOT EXCEED 0.20. DIMENSION b2 LOCATED ABOVE THE DAMBAR PORTION OF MIDDLE LEAD.

DIM	MILLIMETERS		
	MIN.	NOM.	MAX.
A	3.75	3.90	4.05
A1	1.28	1.43	1.58
b	0.38	0.465	0.55
b2	0.62	0.70	0.78
c	0.35	0.40	0.45
D	7.85	8.00	8.15
E	4.75	4.90	5.05
E2	3.90	---	---
e	1.27 BSC		
L	13.80	14.00	14.20

STYLES AND MARKING ON PAGE 3

DOCUMENT NUMBER:	98AON52857E	Electronic versions are uncontrolled except when accessed directly from the Document Repository. Printed versions are uncontrolled except when stamped "CONTROLLED COPY" in red.
DESCRIPTION:	TO-92 (TO-226) 1 WATT	PAGE 1 OF 3

onsemi and ONSEMI are trademarks of Semiconductor Components Industries, LLC dba onsemi or its subsidiaries in the United States and/or other countries. onsemi reserves the right to make changes without further notice to any products herein. onsemi makes no warranty, representation or guarantee regarding the suitability of its products for any particular purpose, nor does onsemi assume any liability arising out of the application or use of any product or circuit, and specifically disclaims any and all liability, including without limitation special, consequential or incidental damages. onsemi does not convey any license under its patent rights nor the rights of others.

TO-92 (TO-226) 1 WATT
CASE 29-10
ISSUE D

DATE 05 MAR 2021

FORMED LEAD

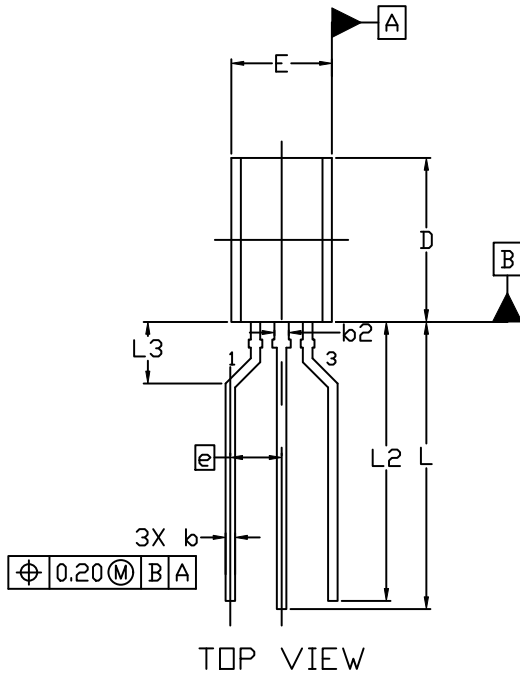
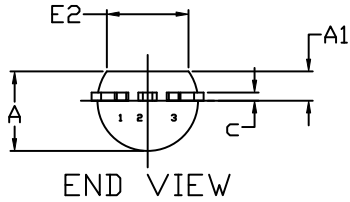

NOTES:

1. DIMENSIONING AND TOLERANCING PER ASME Y14.5M, 2009.
2. CONTROLLING DIMENSION: MILLIMETERS
3. DIMENSIONS D AND E DO NOT INCLUDE MOLD FLASH OR GATE PROTRUSIONS.
4. DIMENSION b AND b2 DOES NOT INCLUDE DAMBAR PROTRUSION. LEAD WIDTH INCLUDING PROTRUSION SHALL NOT EXCEED 0.20. DIMENSION b2 LOCATED ABOVE THE DAMBAR PORTION OF MIDDLE LEAD.

DIM	MILLIMETERS		
	MIN.	NOM.	MAX.
A	3.75	3.90	4.05
A1	1.28	1.43	1.58
b	0.38	0.465	0.55
b2	0.62	0.70	0.78
c	0.35	0.40	0.45
D	7.85	8.00	8.15
E	4.75	4.90	5.05
E2	3.90	---	---
e	2.50 BSC		
L	13.80	14.00	14.20
L2	13.20	13.60	14.00
L3	3.00 REF		

STYLES AND MARKING ON PAGE 3

DOCUMENT NUMBER:	98AON52857E	Electronic versions are uncontrolled except when accessed directly from the Document Repository. Printed versions are uncontrolled except when stamped "CONTROLLED COPY" in red.
DESCRIPTION:	TO-92 (TO-226) 1 WATT	PAGE 2 OF 3

onsemi and ONSEMI are trademarks of Semiconductor Components Industries, LLC dba onsemi or its subsidiaries in the United States and/or other countries. onsemi reserves the right to make changes without further notice to any products herein. onsemi makes no warranty, representation or guarantee regarding the suitability of its products for any particular purpose, nor does onsemi assume any liability arising out of the application or use of any product or circuit, and specifically disclaims any and all liability, including without limitation special, consequential or incidental damages. onsemi does not convey any license under its patent rights nor the rights of others.

**TO-92 (TO-226) 1 WATT
CASE 29-10
ISSUE D**

DATE 05 MAR 2021

- | | | | | |
|---|--|--|---|---|
| STYLE 1:
PIN 1. EMITTER
2. BASE
3. COLLECTOR | STYLE 2:
PIN 1. BASE
2. EMITTER
3. COLLECTOR | STYLE 3:
PIN 1. ANODE
2. ANODE
3. CATHODE | STYLE 4:
PIN 1. CATHODE
2. CATHODE
3. ANODE | STYLE 5:
PIN 1. DRAIN
2. SOURCE
3. GATE |
| STYLE 6:
PIN 1. GATE
2. SOURCE & SUBSTRATE
3. DRAIN | STYLE 7:
PIN 1. SOURCE
2. DRAIN
3. GATE | STYLE 8:
PIN 1. DRAIN
2. GATE
3. SOURCE & SUBSTRATE | STYLE 9:
PIN 1. BASE 1
2. EMITTER
3. BASE 2 | STYLE 10:
PIN 1. CATHODE
2. GATE
3. ANODE |
| STYLE 11:
PIN 1. ANODE
2. CATHODE & ANODE
3. CATHODE | STYLE 12:
PIN 1. MAIN TERMINAL 1
2. GATE
3. MAIN TERMINAL 2 | STYLE 13:
PIN 1. ANODE 1
2. GATE
3. CATHODE 2 | STYLE 14:
PIN 1. EMITTER
2. COLLECTOR
3. BASE | STYLE 15:
PIN 1. ANODE 1
2. CATHODE
3. ANODE 2 |
| STYLE 16:
PIN 1. ANODE
2. GATE
3. CATHODE | STYLE 17:
PIN 1. COLLECTOR
2. BASE
3. EMITTER | STYLE 18:
PIN 1. ANODE
2. CATHODE
3. NOT CONNECTED | STYLE 19:
PIN 1. GATE
2. ANODE
3. CATHODE | STYLE 20:
PIN 1. NOT CONNECTED
2. CATHODE
3. ANODE |
| STYLE 21:
PIN 1. COLLECTOR
2. EMITTER
3. BASE | STYLE 22:
PIN 1. SOURCE
2. GATE
3. DRAIN | STYLE 23:
PIN 1. GATE
2. SOURCE
3. DRAIN | STYLE 24:
PIN 1. EMITTER
2. COLLECTOR/ANODE
3. CATHODE | STYLE 25:
PIN 1. MT 1
2. GATE
3. MT 2 |
| STYLE 26:
PIN 1. V _{CC}
2. GROUND 2
3. OUTPUT | STYLE 27:
PIN 1. MT
2. SUBSTRATE
3. MT | STYLE 28:
PIN 1. CATHODE
2. ANODE
3. GATE | STYLE 29:
PIN 1. NOT CONNECTED
2. ANODE
3. CATHODE | STYLE 30:
PIN 1. DRAIN
2. GATE
3. SOURCE |
| STYLE 31:
PIN 1. GATE
2. DRAIN
3. SOURCE | STYLE 32:
PIN 1. BASE
2. COLLECTOR
3. EMITTER | STYLE 33:
PIN 1. RETURN
2. INPUT
3. OUTPUT | STYLE 34:
PIN 1. INPUT
2. GROUND
3. LOGIC | STYLE 35:
PIN 1. GATE
2. COLLECTOR
3. EMITTER |

**GENERIC
MARKING DIAGRAM***



- XXXX = Specific Device Code
- A = Assembly Location
- L = Wafer Lot
- Y = Year
- W = Work Week
- = Pb-Free Package

(Note: Microdot may be in either location)

*This information is generic. Please refer to device data sheet for actual part marking. Pb-Free indicator, "G" or microdot "▪", may or may not be present. Some products may not follow the Generic Marking.

DOCUMENT NUMBER:	98AON52857E	Electronic versions are uncontrolled except when accessed directly from the Document Repository. Printed versions are uncontrolled except when stamped "CONTROLLED COPY" in red.
DESCRIPTION:	TO-92 (TO-226) 1 WATT	PAGE 3 OF 3

onsemi and **ONSEMI** are trademarks of Semiconductor Components Industries, LLC dba **onsemi** or its subsidiaries in the United States and/or other countries. **onsemi** reserves the right to make changes without further notice to any products herein. **onsemi** makes no warranty, representation or guarantee regarding the suitability of its products for any particular purpose, nor does **onsemi** assume any liability arising out of the application or use of any product or circuit, and specifically disclaims any and all liability, including without limitation special, consequential or incidental damages. **onsemi** does not convey any license under its patent rights nor the rights of others.

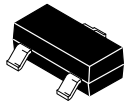

SCALE 4:1

SOT-23 (TO-236) 2.90x1.30x1.00 1.90P
CASE 318
ISSUE AU

DATE 14 AUG 2024

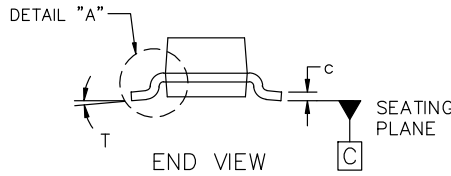
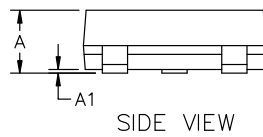
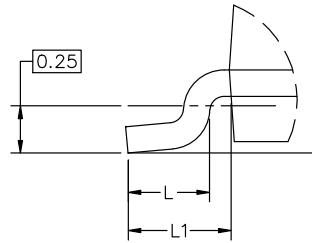
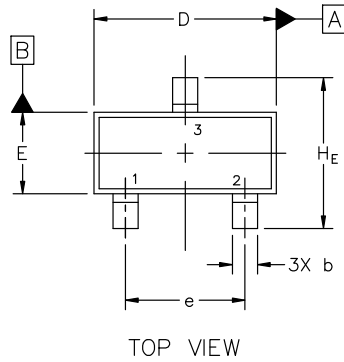

MILLIMETERS			
DIM	MIN	NOM	MAX
A	0.89	1.00	1.11
A1	0.01	0.06	0.10
b	0.37	0.44	0.50
c	0.08	0.14	0.20
D	2.80	2.90	3.04
E	1.20	1.30	1.40
e	1.78	1.90	2.04
L	0.30	0.43	0.55
L1	0.35	0.54	0.69
HE	2.10	2.40	2.64
T	0°	---	10°

NOTES:

1. DIMENSIONING AND TOLERANCING PER ASME Y14.5M, 2018.
2. CONTROLLING DIMENSIONS: MILLIMETERS.
3. MAXIMUM LEAD THICKNESS INCLUDES LEAD FINISH. MINIMUM LEAD THICKNESS IS THE MINIMUM THICKNESS OF THE BASE MATERIAL.
4. DIMENSIONS D AND E DO NOT INCLUDE MOLD FLASH, PROTRUSIONS, OR GATE BURRS.

GENERIC MARKING DIAGRAM*

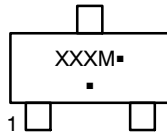

XXX = Specific Device Code
M = Date Code
▪ = Pb-Free Package

*This information is generic. Please refer to device data sheet for actual part marking. Pb-Free indicator, "G" or microdot "▪", may or may not be present. Some products may not follow the Generic Marking.

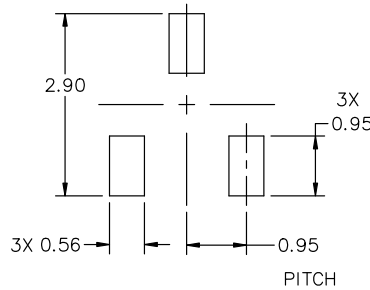

* For additional information on our Pb-Free strategy and soldering details, please download the onsemi Soldering and Mounting Techniques Reference Manual, SOLDERRM/D.

STYLES ON PAGE 2

DOCUMENT NUMBER:	98ASB42226B	Electronic versions are uncontrolled except when accessed directly from the Document Repository. Printed versions are uncontrolled except when stamped "CONTROLLED COPY" in red.
DESCRIPTION:	SOT-23 (TO-236) 2.90x1.30x1.00 1.90P	PAGE 1 OF 2

onsemi and ONSEMI are trademarks of Semiconductor Components Industries, LLC dba onsemi or its subsidiaries in the United States and/or other countries. onsemi reserves the right to make changes without further notice to any products herein. onsemi makes no warranty, representation or guarantee regarding the suitability of its products for any particular purpose, nor does onsemi assume any liability arising out of the application or use of any product or circuit, and specifically disclaims any and all liability, including without limitation special, consequential or incidental damages. onsemi does not convey any license under its patent rights nor the rights of others.

SOT-23 (TO-236) 2.90x1.30x1.00 1.90P
CASE 318
ISSUE AU

DATE 14 AUG 2024

STYLE 1 THRU 5:
CANCELLED

STYLE 6:
PIN 1. BASE
2. EMITTER
3. COLLECTOR

STYLE 7:
PIN 1. EMITTER
2. BASE
3. COLLECTOR

STYLE 8:
PIN 1. ANODE
2. NO CONNECTION
3. CATHODE

STYLE 9:
PIN 1. ANODE
2. ANODE
3. CATHODE

STYLE 10:
PIN 1. DRAIN
2. SOURCE
3. GATE

STYLE 11:
PIN 1. ANODE
2. CATHODE
3. CATHODE-ANODE

STYLE 12:
PIN 1. CATHODE
2. CATHODE
3. ANODE

STYLE 13:
PIN 1. SOURCE
2. DRAIN
3. GATE

STYLE 14:
PIN 1. CATHODE
2. GATE
3. ANODE

STYLE 15:
PIN 1. GATE
2. CATHODE
3. ANODE

STYLE 16:
PIN 1. ANODE
2. CATHODE
3. CATHODE

STYLE 17:
PIN 1. NO CONNECTION
2. ANODE
3. CATHODE

STYLE 18:
PIN 1. NO CONNECTION
2. CATHODE
3. ANODE

STYLE 19:
PIN 1. CATHODE
2. ANODE
3. CATHODE-ANODE

STYLE 20:
PIN 1. CATHODE
2. ANODE
3. GATE

STYLE 21:
PIN 1. GATE
2. SOURCE
3. DRAIN

STYLE 22:
PIN 1. RETURN
2. OUTPUT
3. INPUT

STYLE 23:
PIN 1. ANODE
2. ANODE
3. CATHODE

STYLE 24:
PIN 1. GATE
2. DRAIN
3. SOURCE

STYLE 25:
PIN 1. ANODE
2. CATHODE
3. GATE

STYLE 26:
PIN 1. CATHODE
2. ANODE
3. NO CONNECTION

STYLE 27:
PIN 1. CATHODE
2. CATHODE
3. CATHODE

STYLE 28:
PIN 1. ANODE
2. ANODE
3. ANODE

DOCUMENT NUMBER:	98ASB42226B	Electronic versions are uncontrolled except when accessed directly from the Document Repository. Printed versions are uncontrolled except when stamped "CONTROLLED COPY" in red.
DESCRIPTION:	SOT-23 (TO-236) 2.90x1.30x1.00 1.90P	PAGE 2 OF 2

onsemi and **ONSEMI** are trademarks of Semiconductor Components Industries, LLC dba **onsemi** or its subsidiaries in the United States and/or other countries. **onsemi** reserves the right to make changes without further notice to any products herein. **onsemi** makes no warranty, representation or guarantee regarding the suitability of its products for any particular purpose, nor does **onsemi** assume any liability arising out of the application or use of any product or circuit, and specifically disclaims any and all liability, including without limitation special, consequential or incidental damages. **onsemi** does not convey any license under its patent rights nor the rights of others.

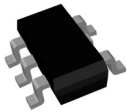

TSOP-5 3.00x1.50x0.95, 0.95P
CASE 483
ISSUE P

DATE 01 APR 2024

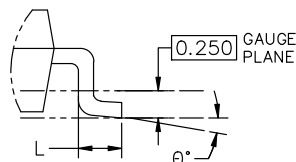
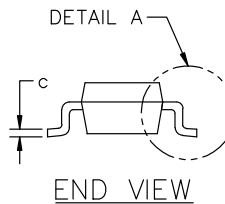
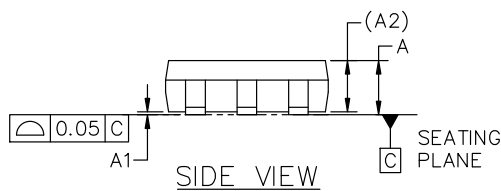
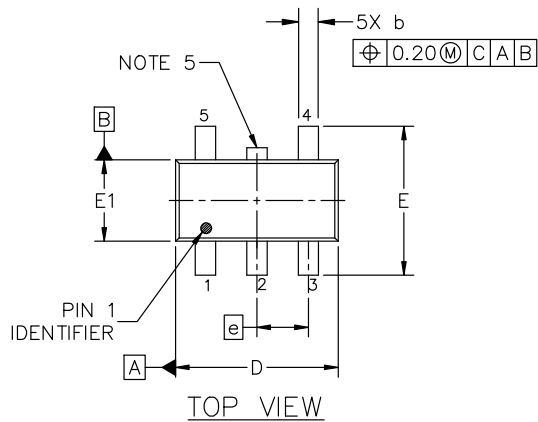

DETAIL "A"
SCALE 2:1

GENERIC
MARKING DIAGRAM*



XXX = Specific Device Code XXX = Specific Device Code
A = Assembly Location M = Date Code
Y = Year ■ = Pb-Free Package
W = Work Week

■ = Pb-Free Package

(Note: Microdot may be in either location)
*This information is generic. Please refer to device data sheet for actual part marking. Pb-Free indicator, "G" or microdot "■", may or may not be present. Some products may not follow the Generic Marking.

NOTES:

1. DIMENSIONING AND TOLERANCING CONFORM TO ASME Y14.5-2018.
2. ALL DIMENSION ARE IN MILLIMETERS (ANGLES IN DEGREES).
3. MAXIMUM LEAD THICKNESS INCLUDES LEAD FINISH THICKNESS. MINIMUM LEAD THICKNESS IS THE MINIMUM THICKNESS OF BASE MATERIAL.
4. DIMENSIONS D AND E1 DO NOT INCLUDE MOLD FLASH, PROTRUSIONS OF GATE BURRS. MOLD FLASH, PROTRUSIONS, OR GATE BURRS SHALL NOT EXCEED 0.15 PER SIDE. DIMENSION D.
5. OPTIONAL CONSTRUCTION: AN ADDITIONAL TRIMMED LEAD IS ALLOWED IN THIS LOCATION. TRIMMED LEAD NOT TO EXTEND MORE THAN 0.2 FROM BODY.

DIM	MILLIMETERS		
	MIN.	NOM.	MAX.
A	0.900	1.000	1.100
A1	0.010	0.055	0.100
A2	0.950 REF.		
b	0.250	0.375	0.500
c	0.100	0.180	0.260
D	2.850	3.000	3.150
E	2.500	2.750	3.000
E1	1.350	1.500	1.650
e	0.950 BSC		
L	0.200	0.400	0.600
θ	0°	5°	10°

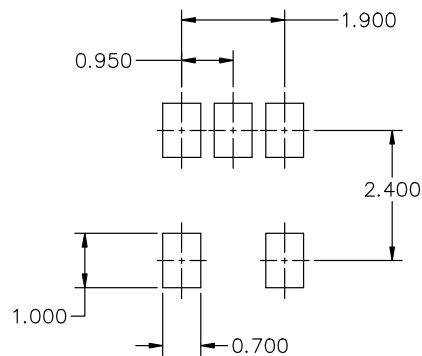

RECOMMENDED MOUNTING FOOTPRINT*

* FOR ADDITIONAL INFORMATION ON OUR Pb-FREE STRATEGY AND SOLDERING DETAILS, PLEASE DOWNLOAD THE ON SEMICONDUCTOR SOLDERING AND MOUNTING TECHNIQUES REFERENCE MANUAL, SOLDERM/D.

DOCUMENT NUMBER:	98ARB18753C	Electronic versions are uncontrolled except when accessed directly from the Document Repository. Printed versions are uncontrolled except when stamped "CONTROLLED COPY" in red.
DESCRIPTION:	TSOP-5 3.00x1.50x0.95, 0.95P	PAGE 1 OF 1

onsemi and onSEMI are trademarks of Semiconductor Components Industries, LLC dba onsemi or its subsidiaries in the United States and/or other countries. onsemi reserves the right to make changes without further notice to any products herein. onsemi makes no warranty, representation or guarantee regarding the suitability of its products for any particular purpose, nor does onsemi assume any liability arising out of the application or use of any product or circuit, and specifically disclaims any and all liability, including without limitation special, consequential or incidental damages. onsemi does not convey any license under its patent rights nor the rights of others.

onsemi, **Onsemi**, and other names, marks, and brands are registered and/or common law trademarks of Semiconductor Components Industries, LLC dba "**onsemi**" or its affiliates and/or subsidiaries in the United States and/or other countries. **onsemi** owns the rights to a number of patents, trademarks, copyrights, trade secrets, and other intellectual property. A listing of **onsemi**'s product/patent coverage may be accessed at www.onsemi.com/site/pdf/Patent-Marking.pdf. **onsemi** reserves the right to make changes at any time to any products or information herein, without notice. The information herein is provided "as-is" and **onsemi** makes no warranty, representation or guarantee regarding the accuracy of the information, product features, availability, functionality, or suitability of its products for any particular purpose, nor does **onsemi** assume any liability arising out of the application or use of any product or circuit, and specifically disclaims any and all liability, including without limitation special, consequential or incidental damages. Buyer is responsible for its products and applications using **onsemi** products, including compliance with all laws, regulations and safety requirements or standards, regardless of any support or applications information provided by **onsemi**. "Typical" parameters which may be provided in **onsemi** data sheets and/or specifications can and do vary in different applications and actual performance may vary over time. All operating parameters, including "Typicals" must be validated for each customer application by customer's technical experts. **onsemi** does not convey any license under any of its intellectual property rights nor the rights of others. **onsemi** products are not designed, intended, or authorized for use as a critical component in life support systems or any FDA Class 3 medical devices or medical devices with a same or similar classification in a foreign jurisdiction or any devices intended for implantation in the human body. Should Buyer purchase or use **onsemi** products for any such unintended or unauthorized application, Buyer shall indemnify and hold **onsemi** and its officers, employees, subsidiaries, affiliates, and distributors harmless against all claims, costs, damages, and expenses, and reasonable attorney fees arising out of, directly or indirectly, any claim of personal injury or death associated with such unintended or unauthorized use, even if such claim alleges that **onsemi** was negligent regarding the design or manufacture of the part. **onsemi** is an Equal Opportunity/Affirmative Action Employer. This literature is subject to all applicable copyright laws and is not for resale in any manner.

ADDITIONAL INFORMATION

TECHNICAL PUBLICATIONS:

Technical Library: www.onsemi.com/design/resources/technical-documentation
onsemi Website: www.onsemi.com

ONLINE SUPPORT: www.onsemi.com/support

For additional information, please contact your local Sales Representative at www.onsemi.com/support/sales

