

THIS DOCUMENT IS THE PROPERTY OF KEYSTONE ELECTRONICS CORP. AND SHALL NOT BE REPRODUCED, DISTRIBUTED OR USED AS A BASIS FOR MANUFACTURE WITHOUT PRIOR WRITTEN PERMISSION FROM KEYSTONE ELECTRONICS CORP.

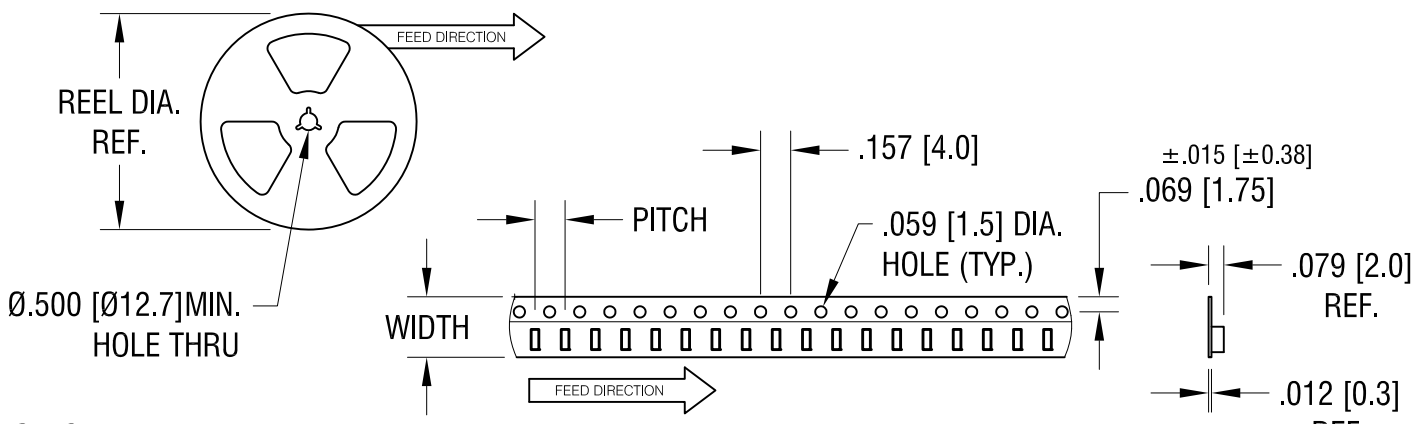
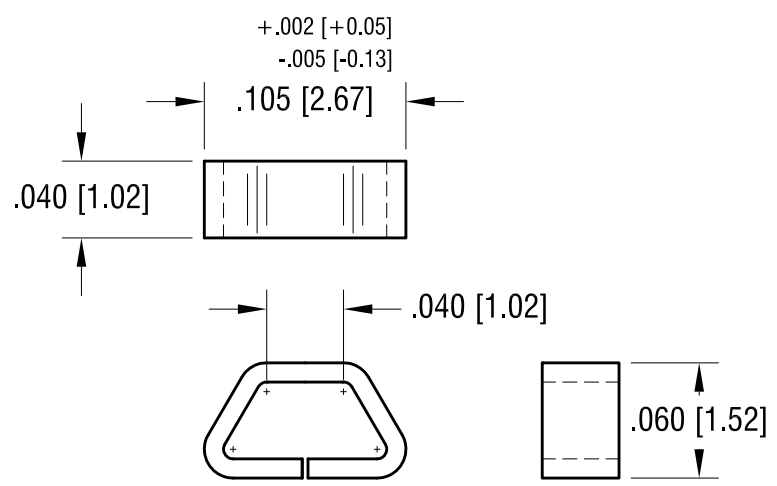
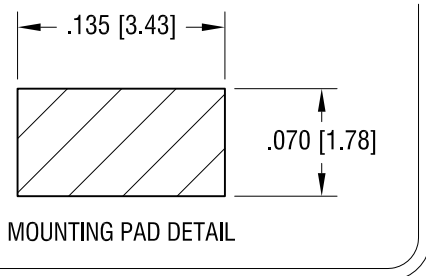

NOTES:

1. SUPPLIED ON TAPE AND REEL ONLY.  
TAPE AND REEL SPECIFICATIONS:
2. TAPE:  
MAT'L - ALL CONDUCTIVE POLYSTYRENE CARRIER  
ANSI/EIA-481 STANDARD  
.315 [8.0] WIDE; .157 [4.0] PITCH
3. REEL:  
7.0 [177.8] DIA. 1000 PIECES PER REEL

<b>KEYSTONE ELECTRONICS CORP.</b>			
www.keyelco.com • NEW HYDE PARK, NY 11040 • Tel (516) 328-7500			
PART NAME			
TEST POINT, MINIATURE, SURFACE MOUNT			
MATERIAL			
.010 [0.25] TH'K PHOSPHOR BRONZE			
FINISH		DRN BY	DATE
MATTE TIN		NT	11.06.19
		APP'D	SCALE
		RH	10X, 1X
TOLERANCES	INCH [MM]	CODE	DWG NO.
DECIMAL	± .005 [± 0.13]	C	<b>5084</b>
ANGULAR	± 1°		
UNLESS OTHERWISE SPECIFIED			

DATE	DESCRIPTION	REV.	
------	-------------	------	--

# Mouser Electronics

Authorized Distributor

Click to View Pricing, Inventory, Delivery & Lifecycle Information:

[Keystone Electronics:](#)

[5084](#)