

DATA SHEET

SURFACE MOUNT MULTILAYER CERAMIC CAPACITORS

Automotive grade
High Temperature Application

X8G / X8R

16 V TO 100 V

680 pF to 100 nF

RoHS compliant & Halogen Free



SCOPE

This specification describes Automotive grade X8G / X8R series chip capacitors with lead-free terminations and used for automotive equipments.

APPLICATIONS

All general-purpose applications under normal operation and usage conditions for automotive equipment's.

FEATURES

- AEC-Q200 qualified
- Operating temperature range: -55 to 150°C
- MSL class: MSL 1
- Soldering is compliant with J-STD-020D
- RoHS compliant
- High component and equipment reliability
- The capacitors are 100% performed by automatic optical inspection prior to taping.

ORDERING INFORMATION - GLOBAL PART NUMBER

All part numbers are identified by the series, size, tolerance, TC material, packing style, voltage, process code, termination and capacitance value.

GLOBAL PART NUMBER

AC XXXX X X XXX X **B X XXX**
 (1) (2) (3) (4) (5) (6) (7)

(1) SIZE – INCH BASED (METRIC)

0603 (1608)
0805 (2012)

(2) TOLERANCE

X8G	X8R
J = ± 5%	K = ± 10%
G = ± 2%	M = ± 20%
F = ± 1%	J = ± 5%

(3) PACKING STYLE (SEE TABLE 6)

R = Paper/PE taping reel; Reel 7 inch
 K = Blister taping reel; Reel 7 inch
 P = Paper/PE taping reel; Reel 13 inch
 F = Blister taping reel; Reel 13 inch

(4) TC MATERIAL

X8G : 0±30 ppm/°C
 X8R : ±15%

(5) RATED VOLTAGE

7 = 16 V
 8 = 25 V
 9 = 50 V
 0 = 100 V

(6) PROCESS

N = Class I MLCC (X8G)
 B = Class II MLCC (X8R)

(7) CAPACITANCE VALUE

2 significant digits+number of zeros
 The 3rd digit signifies the multiplying factor, and letter R is decimal point
 Example: 121 = 12 × 10¹ = 120 pF

CONSTRUCTION

The capacitor consists of a rectangular block of ceramic dielectric in which a number of interleaved metal electrodes are contained. This structure gives rise to a high capacitance per unit volume.

The inner electrodes are connected to the two end terminations and finally covered with a layer of plated tin (Matte Sn). The terminations are lead-free. A cross section of the structure is shown in Fig.1.

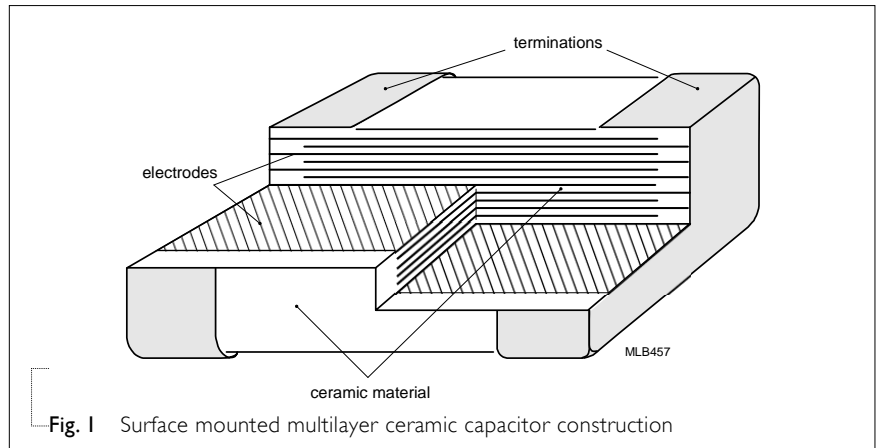

Fig. 1 Surface mounted multilayer ceramic capacitor construction

DIMENSION

Table I For outlines see fig. 2

TYPE	L ₁ (mm)	W (mm)	T (MM)	L ₂ / L ₃ (mm)		L ₄ (mm)
				min.	max.	min.
0603	1.6 ±0.10	0.80 ±0.10	0.80 ±0.10	0.20	0.50	0.60
	2.0 ±0.10	1.25 ±0.10	0.60 ±0.10			
0805	2.0 ±0.20	1.25 ±0.20	0.85 ±0.10	0.25	0.75	0.70
	2.0 ±0.20	1.25 ±0.20	1.25 ±0.20			

OUTLINES

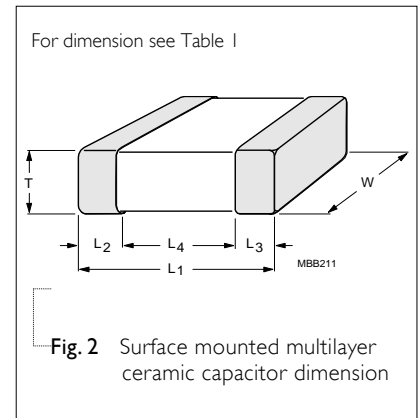

Fig. 2 Surface mounted multilayer ceramic capacitor dimension

CAPACITANCE RANGE & THICKNESS FOR X8G

Table 2-1 Size from 0603 to 0805

CAP.	0603		0805	
	25 V	50 V	50 V	100 V
680 pF	0.8±0.1	0.8±0.1		
1 nF	0.8±0.1	0.8±0.1	0.6±0.1	0.6±0.1
1.2 nF	0.8±0.1	0.8±0.1	0.6±0.1	0.6±0.1
1.5 nF	0.8±0.1	0.8±0.1	0.6±0.1	0.6±0.1
1.8 nF	0.8±0.1	0.8±0.1	0.6±0.1	0.6±0.1
2.7 nF	0.8±0.1	0.8±0.1	0.6±0.1	0.6±0.1
3.3 nF	0.8±0.1	0.8±0.1	0.6±0.1	0.6±0.1
3.9 nF	0.8±0.1	0.8±0.1	0.6±0.1	0.6±0.1
4.7 nF	0.8±0.1	0.8±0.1	0.6±0.1	0.6±0.1
5.6 nF	0.8±0.1	0.8±0.1	0.6±0.1	0.6±0.1
6.8 nF	0.8±0.1	0.8±0.1	0.85±0.1	0.85±0.1
8.2 nF	0.8±0.1	0.8±0.1	0.85±0.1	0.85±0.1
10 nF	0.8±0.1	0.8±0.1	0.85±0.1	0.85±0.1

NOTE

1. Values in shaded cells indicate thickness class in mm
2. Capacitance value of non E-12 series is on request

CAPACITANCE RANGE & THICKNESS FOR X8R

Table 2-2 Size 0805

CAP.	0805		
	16 V	25 V	50 V
22 nF	1.25±0.2	1.25±0.2	1.25±0.2
33 nF	1.25±0.2	1.25±0.2	1.25±0.2
47 nF	1.25±0.2	1.25±0.2	1.25±0.2
68 nF	1.25±0.2	1.25±0.2	1.25±0.2
100 nF	1.25±0.2	1.25±0.2	1.25±0.2

NOTE

1. Values in shaded cells indicate thickness class in mm
2. Capacitance value of non E-6 series is on request

ELECTRICAL CHARACTERISTICS**X8G / X8R DIELECTRIC CAPACITORS; NI/SIN TERMINATIONS**

Unless otherwise specified, all test and measurements shall be made under standard atmospheric conditions for testing as given in 5.3 of IEC 60068-1:

- Temperature: 15 °C to 35 °C
- Relative humidity: 25% to 75%
- Air pressure: 86 kPa to 106 kPa

Before the measurements are made, the capacitor shall be stored at the measuring temperature for a time sufficient to allow the entire capacitor to reach this temperature.

The period as prescribed for recovery at the end of a test is normally sufficient for this purpose.

Table 3

DESCRIPTION		VALUE
Capacitance range		680pF to 100 nF
Dissipation factor (D.F.)		
X8G	C < 30 pF	$\leq 1 / (400 + 20C)$
	C ≥ 30 pF	≤ 0.1 %
X8R		0805
16V	22 nF to 100 nF	≤ 2.5%
25V	22 nF to 100 nF	≤ 2.5%
50V	22 nF to 100 nF	≤ 2.5%
Insulation resistance after 1 minute at U_r (DC)		I.R. ≥ 10 GΩ or I.R. × C ≥ 500 seconds whichever is less
Maximum capacitance change as a function of temperature (temperature characteristic/coefficient):		
X8G		±30 ppm/°C
X8R		±15%
Operating temperature range:		
X8G / X8R		-55 °C to +150 °C

SOLDERING RECOMMENDATION

Table 4

SOLDERING METHOD	SIZE 0402	0603	0805	1206	≥ 1210
Reflow	≥ 0.1 μF	≥ 1.0 μF	≥ 2.2 μF	≥ 4.7 μF	Reflow only
Reflow/Wave	< 0.1 μF	< 1.0 μF	< 2.2 μF	< 4.7 μF	---

SOLDERING CONDITIONS

The lead free MLCCs are able to stand the reflow soldering conditions as below:

- Temperature: above 220 °C
- Endurance: 95 to 120 seconds
- Cycles: 3 times

The test of "soldering heat resistance" is carried out in accordance with the schedule of "MIL-STD-202G-method 210F", "The robust construction of chip capacitors allows them to be completely immersed in a solder bath of 260 °C for 10 seconds". Therefore, it is possible to mount MLCCs on one side of a PCB and other discrete components on the reverse (mixed PCBs). Surface Mount Capacitors are tested for solderability at 245 °C during 2 seconds. The test condition for no leaching is 260°C for 30 seconds.

TESTS AND REQUIREMENTS

Table 5 Test procedures and requirements

TEST	TEST METHOD		PROCEDURE	REQUIREMENTS
Mounting	IEC 60384-21/22	4.3	The capacitors may be mounted on printed-circuit boards or ceramic substrates	No visible damage
Capacitance	IEC 60384-21/22	4.5.1	X8G: At 20 °C, 24 hours after annealing f = 1 MHz for C ≤ 1nF, measuring at voltage V _{rms} at 20 °C f = 1 KHz for C > 1nF, measuring at voltage V _{rms} at 20 °C X8R: At 20 °C, 24 hours after annealing f = 1 KHz, measuring at voltage V _{rms} at 20 °C	Within specified tolerance
Dissipation Factor (D.F.)	IEC 60384-21/22	4.5.2	X8G: At 20 °C, 24 hours after annealing f = 1 MHz for C ≤ 1nF, measuring at voltage V _{rms} at 20 °C f = 1 KHz for C > 1nF, measuring at voltage V _{rms} at 20 °C X8R: At 20 °C, 24 hours after annealing f = 1 KHz, measuring at voltage V _{rms} at 20 °C	In accordance with specification on Table 3
Insulation Resistance	IEC 60384-21/22	4.5.3	At U _r (DC) for 1 minute	In accordance with specification on Table 3

TEST	TEST METHOD	PROCEDURE	REQUIREMENTS
High Temperature Exposure	AEC-Q200 3	Unpowered ; 1000hours @ T=150°C Measurement at 24±2 hours after test conclusion.	No visual damage ΔC/C : X8G: within ±0.5% or 0.5 pF whichever is greater X8R: ±10% D.F.: within initial specified value I.R.: within initial specified value
Temperature Cycling	AEC-Q200 4	Preconditioning: 150 +0/-10 °C for 1 hour, then keep for 24 ±1 hours at room temperature 1000 cycles with following detail: 30 minutes at lower category temperature 30 minutes at upper category temperature Recovery time 24 ±2 hours	No visual damage ΔC/C X8G: Within ±1% or 0.5pF, whichever is greater. X8R: ±10% D.F. meet initial specified value I.R. meet initial specified value
Destructive Physical Analysis	AEC-Q200 5	Only applies to SMD ceramics. Electrical test not required.	
Moisture Resistance	AEC-Q200 6	T=24 hrs/per cycle; 10 continuous cycles unpowered. Measurement at 24 ±2 hours after test condition.	No visual damage ΔC/C X8G: Within ±3% or 3 pF, whichever is greater X8R: ±15% D.F. Within initial specified value I.R. X8G: ≥ 10,000 MΩ X8R: Meet initial specified value

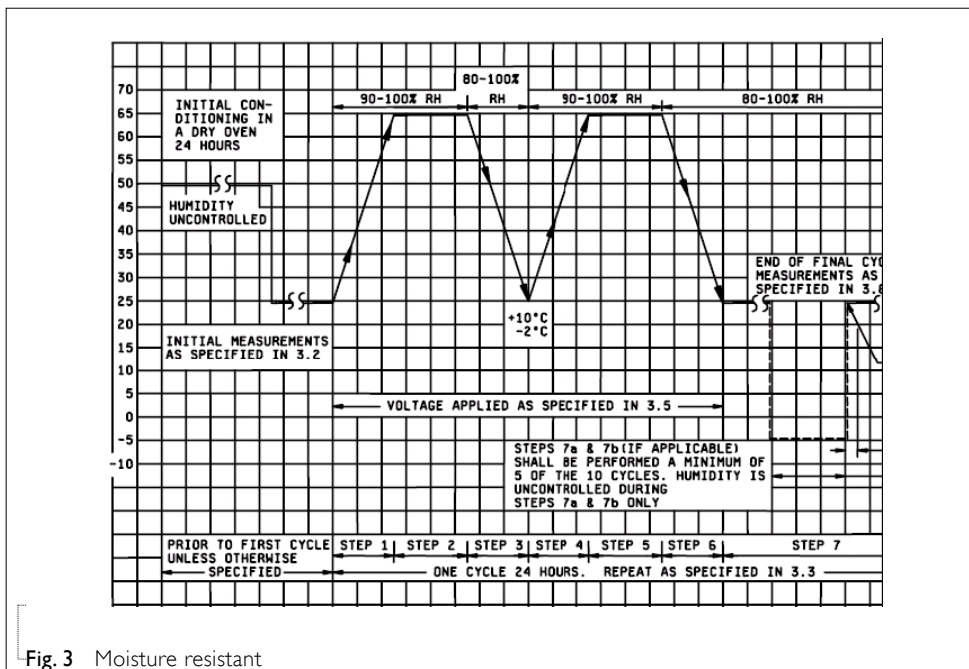
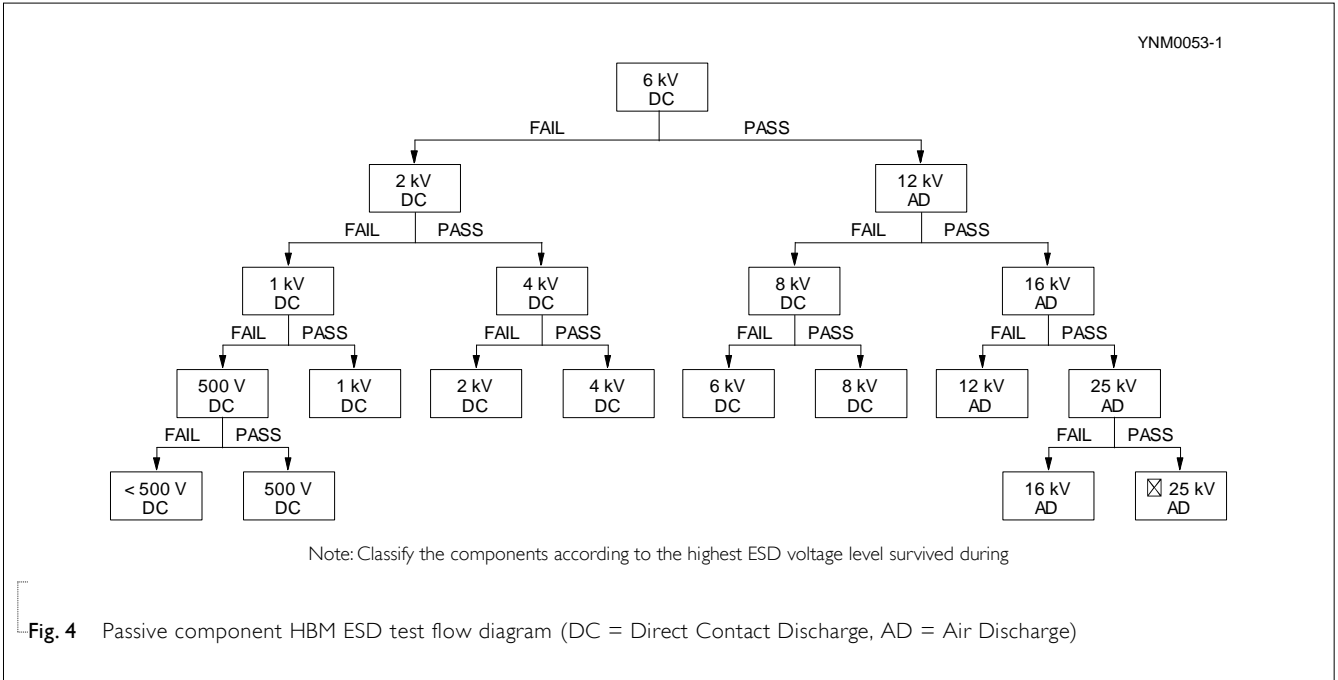

Fig. 3 Moisture resistant

TEST	TEST METHOD		PROCEDURE	REQUIREMENTS
Biased Humidity	AEC-Q200	7	1. Preconditioning, class 2 only: 150 +0/-10 °C /1 hour, then keep for 24 ±1 hour at room temp	No visual damage after recovery
			2. Initial measure: Parameter: I.R. Measuring voltage: 1.5V ± 0.1 VDC Note: Series with 100 KΩ	X8R The insulation resistance shall be greater than 10% of initial spec.
Operational Life	AEC-Q200	8	3. Test condition: 85 °C, 85% R.H. connected with 100 KΩ resistor, applied 1.5V/U _r for 1,000 hours.	
			4. Recovery: X8G: 6 to 24 hours X8R: 24 ±2 hours	
Operational Life	AEC-Q200	8	5. Final measure: I.R.	
			1. Preconditioning, X8R only: 150 +0/-10 °C /1 hour, then keep for 24 ±1 hour at room temp	No visual damage
Operational Life	AEC-Q200	8	2. Initial measure: Spec: refer to initial spec C, D, I.R.	ΔC/C X8G: Within ±2% or 1 pF, whichever is greater
			3. Endurance test: Temperature: X8R: 150 °C Specified stress voltage applied for 1,000 hours: Applied 2.0 × U _r for ≤ 100V series Applied 1.5 × U _r for 200V, 250V series	X8R: ±15%
Operational Life	AEC-Q200	8	4. Recovery time: 24 ±2 hours	D.F. X8G: ≤ 0.2%
			5. Final measure: C, D, I.R.	X8R: within initial specified value
Operational Life	AEC-Q200	8	Note: If the capacitance value is less than the minimum value permitted, then after the other measurements have been made the capacitor shall be preconditioned according to "IEC 60384 4.1" and then the requirement shall be met.	I.R. X8G: ≥ 4,000 MΩ or I.R. × Cr ≥ 40Ω.F whichever is less X8R: ≥ 1,000 MΩ or I.R. × Cr ≥ 50Ω.F whichever is less
			External Visual	AEC-Q200
Physical Dimension	AEC-Q200	10	Verify physical dimensions to the applicable device specification.	In accordance with specification

TEST	TEST METHOD	PROCEDURE	REQUIREMENTS
Mechanical Shock	AEC-Q200 13	Three shocks in each direction shall be applied along the three mutually perpendicular axes of the test specimen (18 shocks) Peak value: 1,500 g's Duration: 0.5 ms Velocity change: 15.4 ft/s Waveform: Half-sin	$\Delta C/C$ X8G: Within $\pm 0.5\%$ or 0.5 pF, whichever is greater X8R: $\pm 10\%$ <hr/> D.F. Within initial specified value I.R. Within initial specified value
Vibration	AEC-Q200 14	5 g's for 20 minutes, 12 cycles each of 3 orientations. Note: Use 8" x 5" PCB. 0.31" thick 7 secure points on one long side and 2 secure points at corners of opposite sides. Parts mounted within 2" from any secure point. Test from 10-2000 Hz.	$\Delta C/C$ X8G: Within $\pm 0.5\%$ or 0.5 pF, whichever is greater X8R: $\pm 10\%$ <hr/> D.F: meet initial specified value I.R. meet initial specified value
Resistance to Soldering Heat	AEC-Q200 15	Precondition: 150 +0/-10 °C for 1 hour, then keep for 24 ± 1 hours at room temperature Preheating: for size ≤ 1206: 120 °C to 150 °C for 1 minute Preheating: for size >1206: 100 °C to 120 °C for 1 minute and 170 °C to 200 °C for 1 minute Solder bath temperature: 260 ± 5 °C Dipping time: 10 ± 0.5 seconds Recovery time: 24 ± 2 hours	Dissolution of the end face plating shall not exceed 25% of the length of the edge concerned <hr/> $\Delta C/C$ X8G: Within $\pm 1\%$ or 0.5 pF, whichever is greater X8R: $\pm 10\%$ <hr/> D.F. within initial specified value I.R. within initial specified value
Thermal Shock	AEC-Q200 16	1. Preconditioning, X8R only: 150 +0/-10 °C / 1 hour, then keep for 24 ± 1 hour at room temp 2. Initial measure: Spec: refer to initial spec C, D, I.R. 3. Rapid change of temperature test: X8G / X8R: -55 °C to +150 °C; 300 cycles 15 minutes at lower category temperature; 15 minutes at upper category temperature. 4. Recovery time: X8G: 6 to 24 hours X8R: 24 ± 2 hours 5. Final measure: C, D, I.R.	No visual damage <hr/> $\Delta C/C$ X8G: Within $\pm 1\%$ or 1 pF, whichever is greater X8R: $\pm 15\%$ <hr/> D.F: meet initial specified value I.R. meet initial specified value

TEST	TEST METHOD	PROCEDURE	REQUIREMENTS
ESD	AEC-Q200 17	Per AEC-Q200-002	A component passes a voltage level if all components stressed at that voltage level pass.



Solderability	AEC-Q200 18	Preheated to a temperature of 80 °C to 140 °C and maintained for 30 seconds to 60 seconds.	The solder should cover over 95% of the critical area of each termination.
		Test conditions for lead containing solder alloy Temperature: 235 ±5 °C Dipping time: 2 ±0.2 seconds Depth of immersion: 10 mm Alloy Composition: 60/40 Sn/Pb Number of immersions: 1 Test conditions for lead-free containing solder alloy Temperature: 245 ±5 °C Dipping time: 3 ±0.3 seconds Depth of immersion: 10 mm Alloy Composition: SAC305 Number of immersions: 1	
Electrical Characterization	AEC-Q200 19	Parametrically test per lot and sample size requirements, summary to show Min, Max, Mean and Standard deviation at room as well as Min and Max operating temperatures.	ΔC/C X8G: ±30 ppm/°C X8R: ±15%
X8G / X8R: -55 °C to +150 °C Normal temperature: 25 °C			

TEST	TEST METHOD	PROCEDURE	REQUIREMENTS
Board Flex	AEC-Q200 21	<p>Part mounted on a 100 mm X 40 mm FR4 PCB board, which is 1.6 ±0.2 mm thick and has a layer-thickness 35 μm ± 10 μm.</p> <p>Part should be mounted using the following soldering reflow profile.</p> <p>Conditions:</p> <p>X8G: Bending 3 mm at a rate of 1 mm/s, radius jig 340 mm</p> <p>X8R: Bending 2 mm at a rate of 1 mm/s, radius jig 340 mm</p>	<p>No visible damage</p> <p>ΔC/C</p> <p>X8G: Within ±1% or 0.5 pF, whichever is greater</p> <p>X8R: ±10%</p>

Test Substrate:

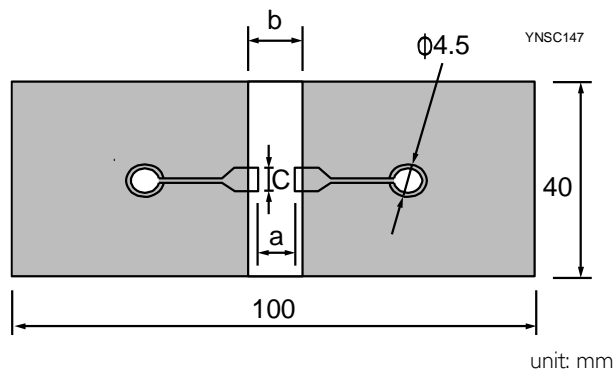

Type	Dimension(mm)		
	a	b	c
0201	0.3	0.9	0.3
0402	0.4	1.5	0.5
0603	1.0	3.0	1.2
0805	1.2	4.0	1.65
1206	2.2	5.0	1.65
1210	2.2	5.0	2.0
1808	3.5	7.0	3.7

Terminal Strength	AEC-Q200 22	<p>With the component mounted on a PCB obtained with the device to be tested, apply a 17.7N (1.8Kg) force to the side of a device being tested.</p> <p>This force shall be applied for 60+1 seconds.</p> <p>Also the force shall be applied gradually as not to apply a shock to the component being tested.</p> <p>* Apply 2N force for 0402 size.</p>	<p>Magnification of 20X or greater may be employed for inspection of the mechanical integrity of the device body, terminals and body/terminal junction.</p> <p>Before, during and after the test, the device shall comply with all electrical requirements stated in this specification.</p>
-------------------	-------------	---	--

Beam Load Test	AEC-Q200 23	<p>Place the part in the beam load fixture. Apply a force until the part breaks or the minimum acceptable force level required in the user specification(s) is attained.</p>	<p>≤ 0805</p> <p>Thickness > 0.5mm: 20N</p> <p>Thickness ≤ 0.5mm: 8N</p> <p>≥ 1206</p> <p>Thickness ≥ 1.25 mm: 54N</p> <p>Thickness < 1.25 mm: 15N</p>
----------------	-------------	--	--

Voltage Proof		<ol style="list-style-type: none"> Specified stress voltage applied for 1~5 seconds Ur ≤ 100 V: series applied 2.5 Ur 100 V < Ur ≤ 200 V series applied (1.5 Ur + 100) 200 V < Ur ≤ 500 V series applied (1.3 Ur + 100) Ur > 500 V: 1.3 Ur Ur ≥ 1000 V: 1.2 Ur <p>Charge/Discharge current is less than 50 mA</p>	No breakdown or flashover
---------------	--	--	---------------------------

THICKNESS CLASSES AND PACKING QUANTITY

Table 6

SIZE CODE	THICKNESS CLASSIFICATION	PACKING CODE		TAPE WIDTH	QUANTITY PER REEL			
		7 INCH	13 INCH		Ø180 MM / 7 INCH		Ø330 MM / 13 INCH	
					Paper	Blister	Paper	Blister
0603	0.80 ±0.1 mm	R	P	8 mm	4,000	---	15,000	---
0805	0.60 ±0.1 mm	R	P	8 mm	4,000	---	20,000	---
	0.85 ±0.1 mm	R	P	8 mm	4,000	---	15,000	---
	1.25 ±0.2 mm	K	F	8 mm	---	3,000	---	10,000

PAPER/PE TAPE SPECIFICATION

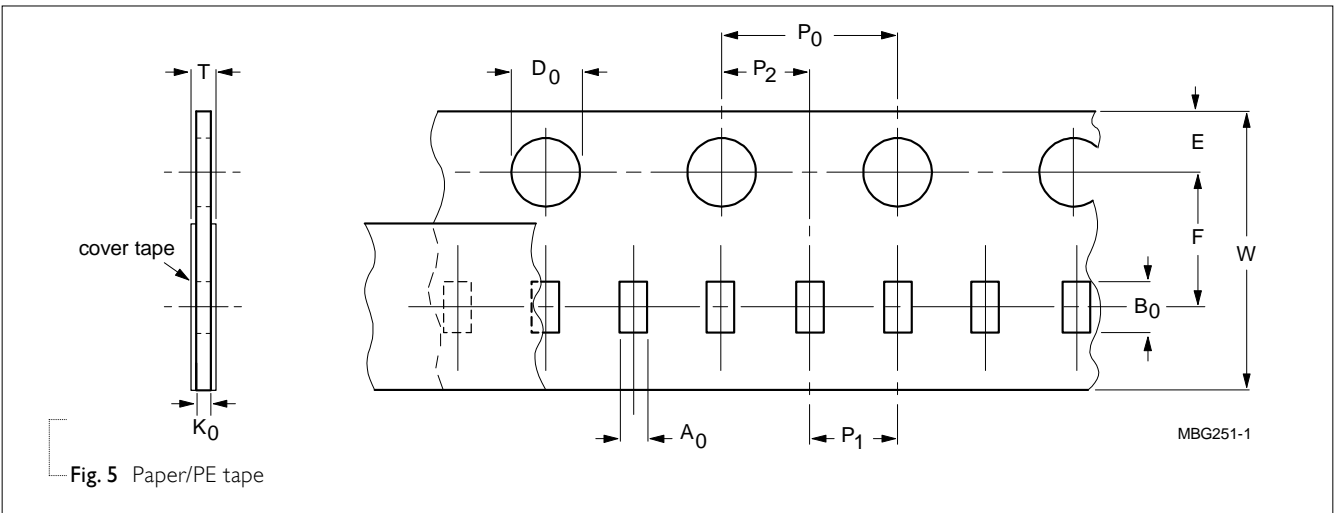

Table 7 Dimensions of paper/PE tape for relevant chip size; see Fig.5

SIZE CODE	SYMBOL											Unit: mm
	A ₀	B ₀	W	E	F	P ₀ ⁽¹⁾	P ₁	P ₂	ØD ₀	K ₀	T	
0201	0.39 ± 0.06	0.70 ± 0.06	8.0 ± 0.20	1.75 ± 0.1	3.50 ± 0.05	4.0 ± 0.05	2.0 ± 0.05	2.0 ± 0.05	1.55 ± 0.03	0.38 ± 0.05	(0.47 / 0.55)±0.10	
0402	0.70 ± 0.15	1.21 ± 0.12	8.0 ± 0.20	1.75 ± 0.1	3.50 ± 0.05	4.0 ± 0.05	2.0 ± 0.05	2.0 ± 0.05	1.50 +0.1 /-0	(0.75 / 0.60)±0.10	(0.85 / 0.70)±0.10	
0603	1.05 ± 0.14	1.86 ± 0.13	8.0 ± 0.20	1.75 ± 0.1	3.50 ± 0.05	4.0 ± 0.10	4.0 ± 0.10	2.0 ± 0.05	1.50 +0.1 /-0	(1.05 / 0.95 / 0.75)±0.10	(1.15 / 1.05 / 0.85)±0.10	
0805	1.50 ± 0.15	2.26 ± 0.20	8.0 ± 0.20	1.75 ± 0.1	3.50 ± 0.05	4.0 ± 0.10	4.0 ± 0.10	2.0 ± 0.05	1.50 +0.1 /-0	(1.05 / 0.95 / 0.75)±0.10	(1.15 / 1.05 / 0.85)±0.10	
1206	1.90 ± 0.15	3.50 ± 0.20	8.0 ± 0.20	1.75 ± 0.1	3.50 ± 0.05	4.0 ± 0.10	4.0 ± 0.10	2.0 ± 0.05	1.50 +0.1 /-0	(0.95 / 0.75)±0.10	(1.05 / 0.85)± 0.10	

NOTE

1. P₀ pitch tolerance over any 10 pitches is ±0.2 mm

BLISTER TAPE SPECIFICATION

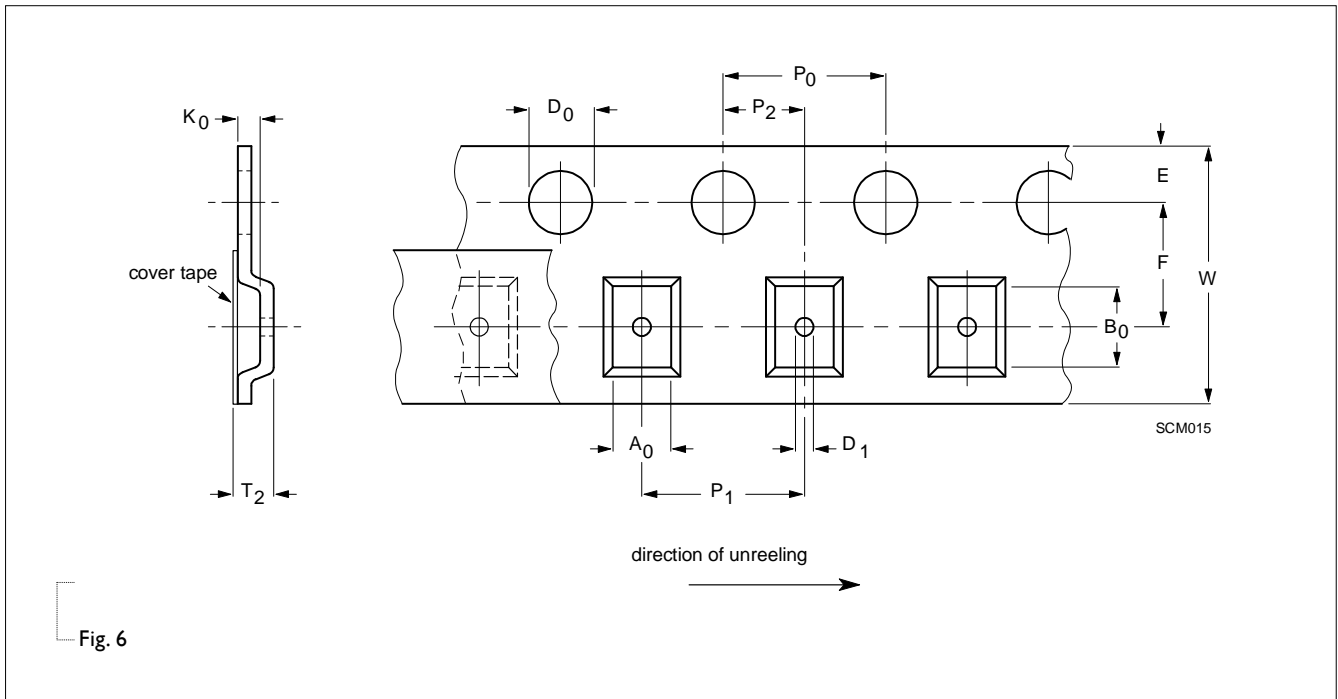

Fig. 6

Table 8 Dimensions of blister tape for relevant chip size; see Fig.6

SIZE CODE	SYMBOL												Unit: mm			
	A0		B0		K0		W	E	F	ØD0	ØD1	P0 (2)	P1	P2	T2	
	Min.	Max.	Min.	Max.	Min.	Max.									Min.	Max.
0805	1.29	1.65	2.09	2.60	1.25	1.62	8.1 ±0.20	1.75 ±0.1	3.5 ±0.05	1.5 +0.1/-0.0	1 +0.1/-0.0	4.0 ±0.10	4.0 ±0.10	2.0 ±0.05	1.30	1.67
1206	1.65	2.12	3.30	3.75	1.22	2.15	8.1 ±0.20	1.75 ±0.1	3.5 ±0.05	1.5 +0.1/-0.0	1 +0.1/-0.0	4.0 ±0.10	4.0 ±0.10	2.0 ±0.05	1.27	2.20
1210	2.55	3.02	3.31	3.88	0.97	2.92	8.1 ±0.20	1.75 ±0.1	3.5 ±0.05	1.5 +0.1/-0.0	1 +0.1/-0.0	4.0 ±0.10	4.0 ±0.10	2.0 ±0.05	1.02	2.97
1808	2.05	2.55	4.80	5.45	1.30	2.45	12.1 ±0.20	1.75 ±0.1	5.5 ±0.05	1.5 +0.1/-0.0	1.5 +0.1/-0.0	4.0 ±0.10	4.0 ±0.10	2.0 ±0.05	1.35	2.50
1812	3.35	3.75	4.70	5.33	0.70	2.40	12.1 ±0.20	1.75 ±0.1	5.5 ±0.05	1.5 +0.1/-0.0	1.5 +0.1/-0.0	4.0 ±0.10	8.0 ±0.10	2.0 ±0.05	0.75	2.45

NOTE

1. Typical capacitor displacement in pocket
2. P0 pitch tolerance over any 10 pitches is ±0.2 mm

REEL SPECIFICATION

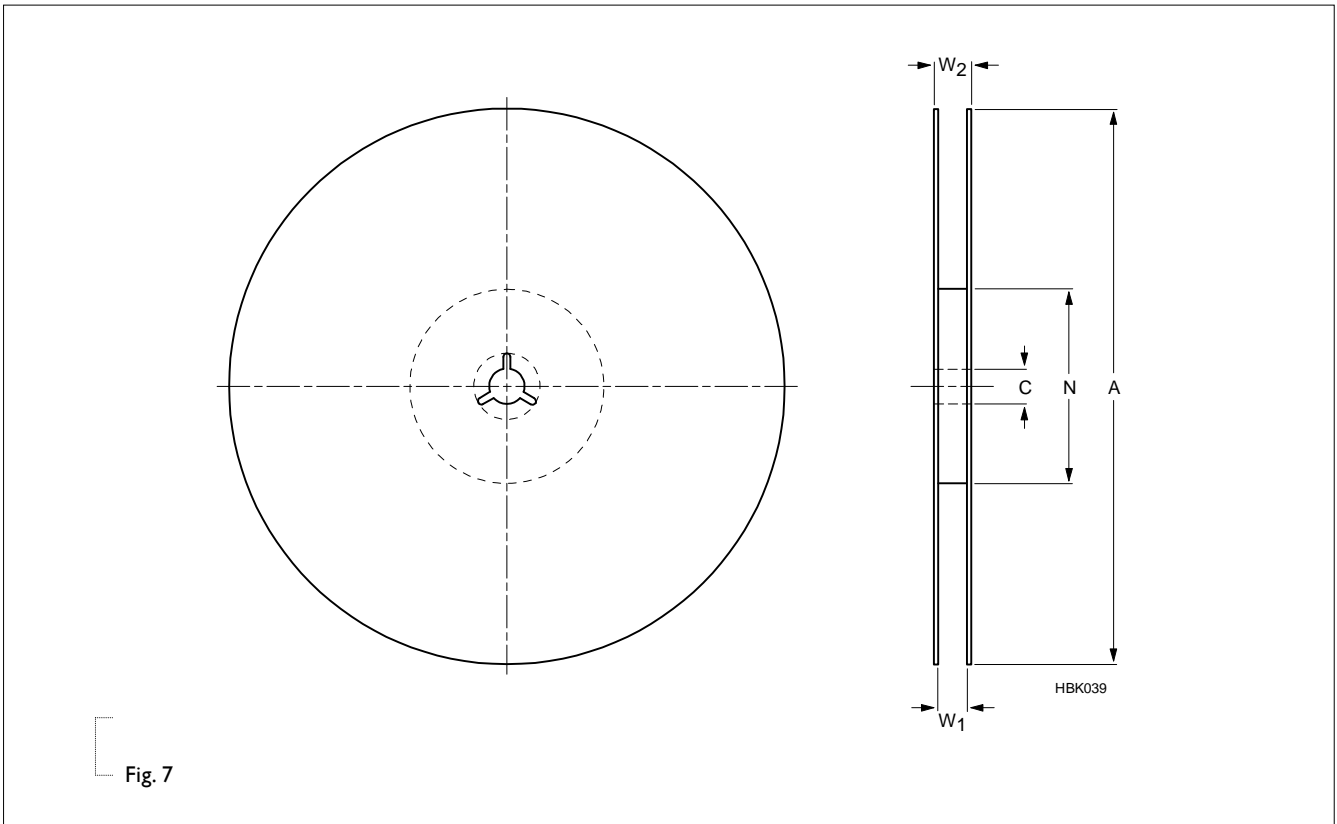

Fig. 7

Table 9 Reel dimensions; see Fig.7

TAPE WIDTH	SYMBOL					Unit: mm
	A	N	C	W ₁	W _{2max.}	
8 (Ø178 mm/7")	178 ±1.0	60 ±1.0	13 +0.50/-0.20	9.4 ±1.5	14.4	
8 (Ø330 mm/13")	330 ±1.0	100 ±1.0	13 +0.50/-0.20	9.0 ±0.2	14.4	
12 (Ø178 mm/7")	178 ±1.0	60 ±1.0	13 +0.50/-0.20	13.4 ±1.5	18.4	

PROPERTIES OF REEL

Material: polystyrene

Surface resistance: <math> <10^{10}</math> χ /sq.

MOUNTING

SOLDER REPAIRS

Conventional solder repairs are carried out with a soldering iron as shown as Table 10. The tip of the soldering iron should not directly touch the chip component to avoid thermal shock on the interface between termination and body during mounting, repairing or de-mounting processes. Ensure the termination solder has melted before removing the chip component.

Table 10 Recommended soldering iron condition

SIZE	Temp(°C)	DURATION (SEC.)	PREHEATING TEMP(°C)	ATMOSPHERE
0201/0402/0603/0805/1206	350 max.	3 max.	150 min.	air
1210/1808/1812/2220	280 max.	3 max.	150 min.	air

SOLDERING CONDITIONS

For normal use the capacitors may be mounted on printed-circuit boards or ceramic substrates by applying wave soldering, reflow soldering or conductive adhesive in accordance with IEC 61760-1 (Standard method for the specification of surface mounting components). For advised soldering profiles see Figs 8, 9, 10.

An improper combination of soldering, substrate and chip size can lead to a damaging of the component. The risk increases with the chip size and with temperature fluctuations (>100 °C).

Therefore, it is advised to use the smallest possible size and follow the dimensional recommendations given in Tables 8, 9 and 10 for reflow and wave soldering. More detailed information is available on request.

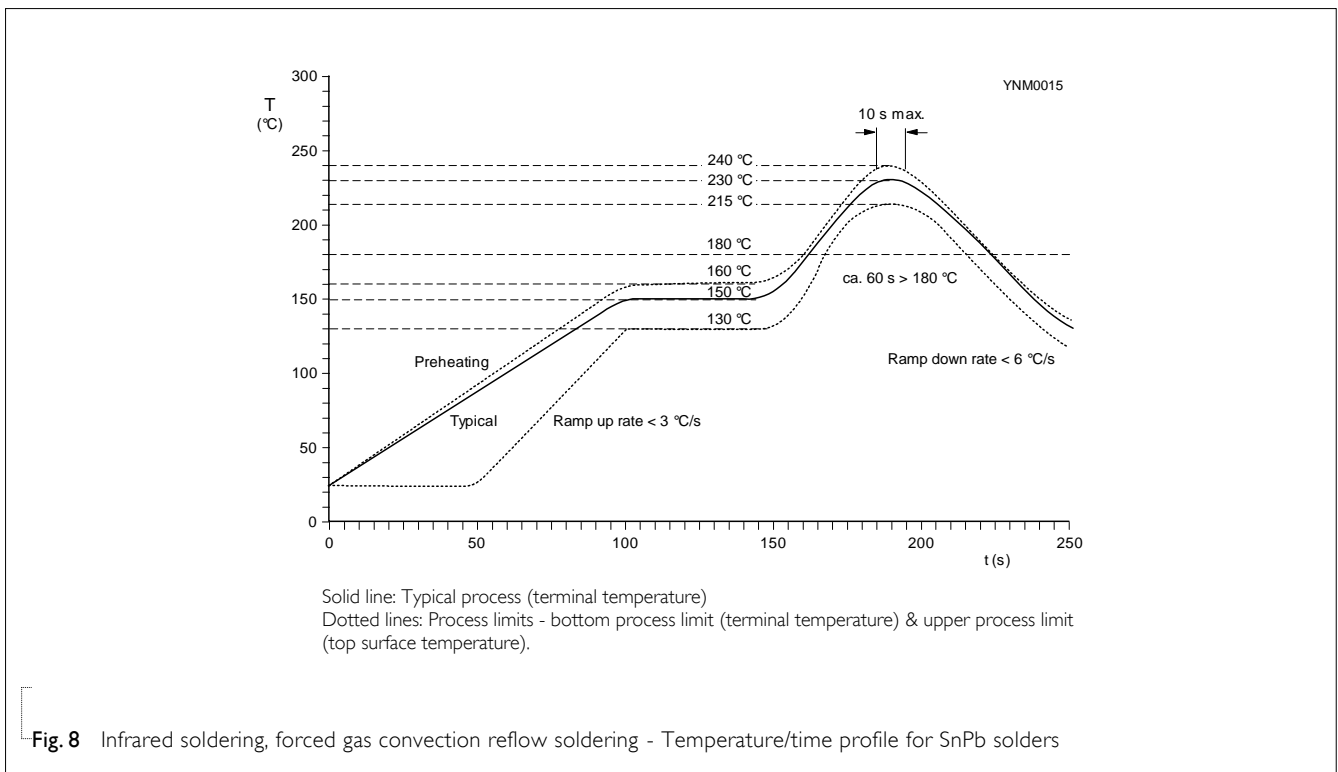

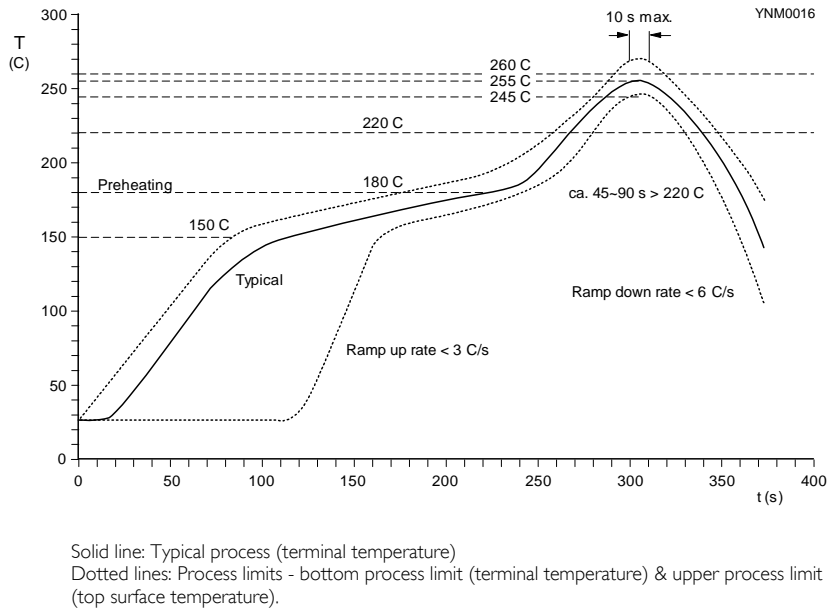

Fig. 9 Infrared soldering, forced gas convection reflow soldering - Temperature/time profile for lead-free SnAgCu solders

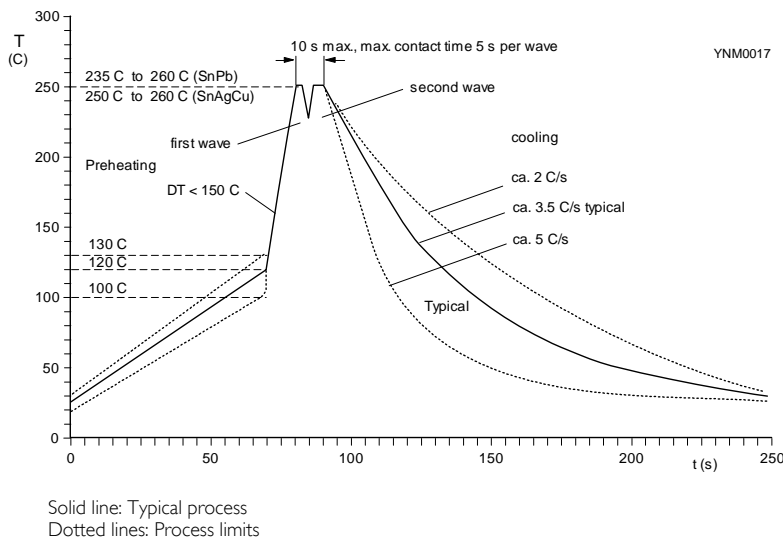

Fig. 10 Double wave soldering for SnPb and lead-free SnAgCu solder - Temperature/time profile (terminal temperature)

FOOTPRINT DIMENSIONS

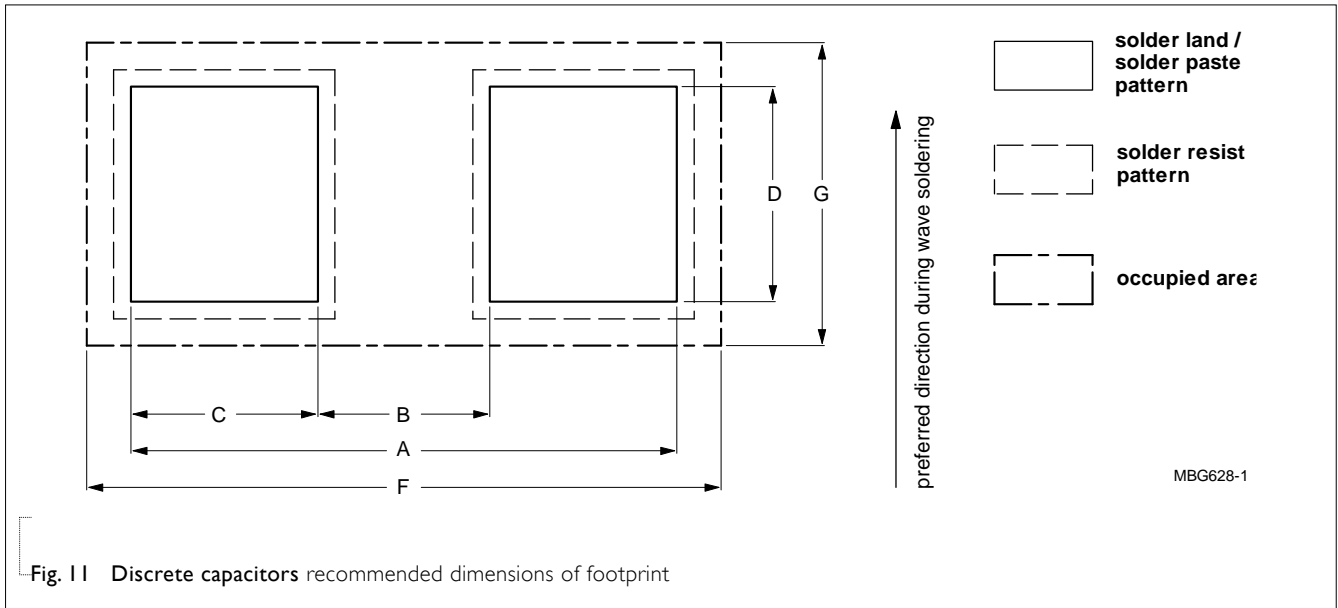

Fig. 11 Discrete capacitors recommended dimensions of footprint

Table 11 Reflow soldering; for footprint dimensions see Fig. 11

SIZE CODE	FOOTPRINT DIMENSIONS						Unit: mm
	A	B	C	D	F	G	Processing remarks
0201	0.8 ±0.20	0.25 ±0.05	0.28 ±0.07	0.3 ±0.10	---	---	
0402	1.5 ±0.15	0.5 ±0.15	0.5 ±0.15	0.5 ±0.15	1.75 ±0.15	0.95 ±0.15	
0603	2.3 ±0.15	0.7 ±0.15	0.8 ±0.15	0.9 ±0.15	2.7 ±0.15	1.5 ±0.15	
0603	2.3 ±0.25	0.5 ±0.25	0.9 ±0.25	0.9 ±0.25	2.7 ±0.25	1.5 ±0.25	IR or hot plate soldering
0805	2.8 ±0.25	0.9 ±0.25	0.95 ±0.25	1.4 ±0.25	3.2 ±0.25	2.1 ±0.25	
1206	4.0 ±0.25	2.0 ±0.25	1.0 ±0.25	1.8 ±0.25	4.4 ±0.25	2.5 ±0.25	
1210	4.0 ±0.25	2.0 ±0.25	1.0 ±0.25	2.7 ±0.25	4.4 ±0.25	3.4 ±0.25	
1808	5.4 ±0.25	3.3 ±0.25	1.05 ±0.25	2.3 ±0.25	5.8 ±0.25	2.9 ±0.25	
1812	5.4 ±0.25	3.3 ±0.25	1.05 ±0.25	3.5 ±0.25	5.8 ±0.25	4.1 ±0.25	Ceramic substrate only
2220	6.6 ±0.25	4.5 ±0.25	1.05 ±0.25	5.3 ±0.25	7.0 ±0.25	5.9 ±0.25	

REVISION HISTORY

REVISION	DATE	CHANGE NOTIFICATION	DESCRIPTION
Version 2	May 01, 2022	-	- Add X8G 0603, 680pF to 10nF, 25V to 50V
Version 1	Oct, 2, 2019	-	- Add X8G product range, 0805, 1nF to 10nF, 50V to 100V
Version 0	Dec. 12, 2018	-	- New

Surface-Mount Ceramic Multilayer Capacitors

LEGAL DISCLAIMER

YAGEO, its distributors and agents (collectively, "YAGEO"), hereby disclaims any and all liabilities for any errors, inaccuracies or incompleteness contained in any product related information, including but not limited to product specifications, datasheets, pictures and/or graphics. YAGEO may make changes, modifications and/or improvements to product related information at any time and without notice.

YAGEO makes no representation, warranty, and/or guarantee about the fitness of its products for any particular purpose or the continuing production of any of its products. To the maximum extent permitted by law, YAGEO disclaims (i) any and all liability arising out of the application or use of any YAGEO product, (ii) any and all liability, including without limitation special, consequential or incidental damages, and (iii) any and all implied warranties, including warranties of fitness for a particular purpose, non-infringement and merchantability.

YAGEO products are designed for general purpose applications under normal operation and usage conditions. Please contact YAGEO for the applications listed below which require especially high reliability for the prevention of defects which might directly cause damage to the third party's life, body or property: Aerospace equipment (artificial satellite, rocket, etc.), Atomic energy-related equipment, Aviation equipment, Disaster prevention equipment, crime prevention equipment, Electric heating apparatus, burning equipment, Highly public information network equipment, data-processing equipment, Medical devices, Military equipment, Power generation control equipment, Safety equipment, Traffic signal equipment, Transportation equipment and Undersea equipment, or for any other application or use in which the failure of YAGEO products could result in personal injury or death, or serious property damage. Particularly **YAGEO Corporation and its affiliates do not recommend the use of commercial or automotive grade products for high reliability applications or manned space flight.**

Information provided here is intended to indicate product specifications only. YAGEO reserves all the rights for revising this content without further notification, as long as products are unchanged. Any product change will be announced by PCN.