

# 1-Mbit serial I<sup>2</sup>C bus EEPROM with configurable device address, software write protection registers, and preprogrammed device address

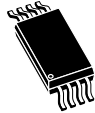

SO8N  
(150 mil width)



TSSOP8  
(169 mil width)

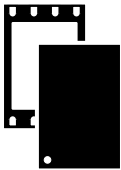

UFDFPN8-DFN8  
(2 x 3 mm)



WLCSP5  
(CS and CP)

## Features

### I<sup>2</sup>C interface

- Compatible with the following I<sup>2</sup>C bus modes:
  - 1 MHz (Fast-mode Plus)
  - 400 kHz (Fast-mode)
  - 100 kHz (Standard-mode)

### Memory

- 1-Mbit (128-Kbyte) of EEPROM
- Page size: 256-byte
- Additional 256-byte identification page

### Supply voltage

- Wide voltage range: 1.6 V to 5.5 V

### Temperature

- Operating temperature range: -40 °C to +85 °C

### Fast write cycle time

- Byte and page write within 4 ms (typically 3 ms)

### Performance

- Enhanced ESD/latch-up protection
- More than 4 million write cycles
- More than 200-year data retention
- Fast wake-up time (less than 5 μs)

### Ultra-low power current consumption

- 350 nA (typical) in standby mode
- 100 μA (typical) for read current
- 400 μA (typical) for write current

### Advanced features

- Configurable device address register
- Device type identifier register (in read-only)
- Preprogrammed device address
- Software write protection register
- Hardware write protection of the whole memory array
- Random and sequential read modes

### Packages

- SO8N, TSSOP8, UFDFPN8, and WLCSP5 (ECOPACK2 compliant)

#### Product status link

M24M01E-F

#### Product label



# 1 Description

The **M24M01E-F** is a 1-Mbit I<sup>2</sup>C-compatible EEPROM (electrically erasable programmable memory) organized as 128 K × 8 bits. It can operate with a supply voltage from 1.6 V to 5.5 V with a clock frequency up to 1 MHz, over an ambient temperature range of -40 °C to +85 °C.

The device offers three 8-bit registers, namely: the device type identifier (DTI) register, the configurable device address (CDA), and the software write protection (SWP) register.

The device offers an additional 256-byte page, called the identification page. This page can be used to store sensitive application parameters, which can later be permanently locked in read-only mode.

The M24M01E-F is available in the standard 8-pin TSSOP8, SO8N, UDFPN8, and in the 5-ball wafer level chip scale packaging (WLCSP) with the WC pin.

On demand, the EEPROM can be delivered with a preprogrammed and locked device address.

**Figure 1. Logic diagram**

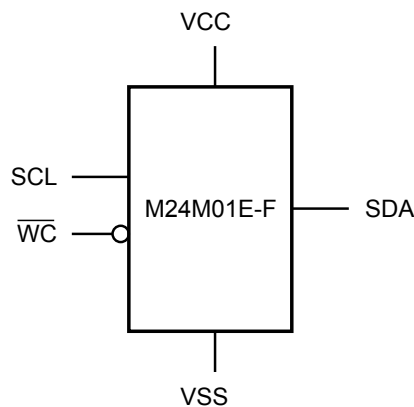

**Table 1. Signal names**

Signal name	Function	Direction
SDA	Serial data	I/O
SCL	Serial clock	Input
$\overline{WC}$	Write control	Input
V <sub>CC</sub>	Supply voltage	-
V <sub>SS</sub>	Ground	-

**Figure 2. 8-pin package connections, top view**

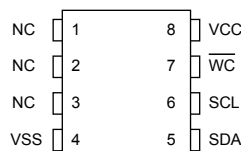

1. NC: Not connected

See [Section 10: Package information](#) for package dimensions, and how to identify pin 1.

DT54532V1

Figure 3. 5-ball package connection

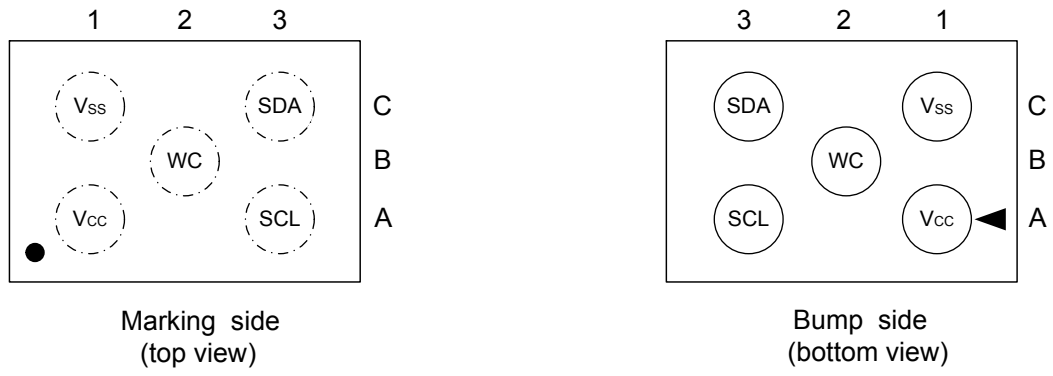

DT73019V1

## 2 Signal description

### 2.1 Serial clock (SCL)

The signal applied on the SCL input is used to strobe the data available on SDA(in) and to output the data on SDA(out).

### 2.2 Serial data (SDA)

SDA is an input/output used to transfer data in or out of the device. SDA(out) is an open drain output that may be wired-AND with other open drain or open collector signals on the bus. A pull-up resistor must be connected from serial data (SDA) to  $V_{CC}$  (Figure 25 and Figure 26 indicate how to calculate the value of the pull-up resistor).

### 2.3 Write control ( $\overline{WC}$ )

This input signal is useful for protecting the contents of the memory, registers, and identification page from inadvertent write operations. All write operations are disabled when the  $\overline{WC}$  is driven high. All write operations are enabled when the  $\overline{WC}$  is either driven low or left floating.

When it is driven high, device select and address bytes are acknowledged, data bytes are not acknowledged.

### 2.4 $V_{SS}$ (ground)

$V_{SS}$  is the reference for the  $V_{CC}$  supply voltage.

## 2.5 Supply voltage ( $V_{CC}$ )

### 2.5.1 Operating supply voltage ( $V_{CC}$ )

Before selecting the memory and issuing instructions to it, a valid and stable  $V_{CC}$  voltage within the specified [ $V_{CC}(\min)$ ,  $V_{CC}(\max)$ ] range must be applied (see operating conditions in [Section 9: DC and AC parameters](#)). To secure a stable DC supply voltage, it is recommended to decouple the  $V_{CC}$  line with a suitable capacitor (from 10 nF to 100 nF) close to the  $V_{CC}/V_{SS}$  package pins.

This voltage must remain stable and valid until the end of the transmission of the instruction and, for a write instruction, until the completion of the internal write cycle ( $t_W$ ).

### 2.5.2 Power-up conditions

The  $V_{CC}$  voltage must rise continuously from 0 V up to the minimum  $V_{CC}$  operating voltage (see operating conditions in [Section 9: DC and AC parameters](#)).

Once the  $V_{CC}$  is greater than or equal to the minimum  $V_{CC}$  level, the controller must wait for at least  $t_{WU}$  before sending the first command to the device. See [Table 19](#) and [Table 20](#) for the value of the wake-up time parameter.

### 2.5.3 Device reset

To prevent inadvertent write operations during power-up, a power-on-reset (POR) circuit is included.

At power-up, the device does not respond to any instruction until  $V_{CC}$  has reached the internal reset threshold voltage. This threshold is lower than the minimum  $V_{CC}$  operating voltage (see operating conditions in [Section 9: DC and AC parameters](#)). When  $V_{CC}$  passes over the POR threshold, the device is reset and enters the standby power mode; the device must not be accessed until  $V_{CC}$  reaches a valid and stable DC voltage within the specified [ $V_{CC}(\min)$ ,  $V_{CC}(\max)$ ] range (see operating conditions in [Section 9: DC and AC parameters](#)).

In a similar way, during power-down (continuous decrease in  $V_{CC}$ ), the device must not be accessed when  $V_{CC}$  drops below  $V_{CC}(\min)$ . When  $V_{CC}$  drops below the power-on-reset threshold voltage, the device stops responding to any instruction sent to it.

### 2.5.4 Power-down conditions

During power-down, when the  $V_{CC}$  decreases down to 0 V, the device must be in the standby power mode. This mode is reached after decoding a stop condition, assuming that there is no internal write cycle in progress.

### 3 Memory organization

The memory is organized as shown below.

Figure 4. Block diagram

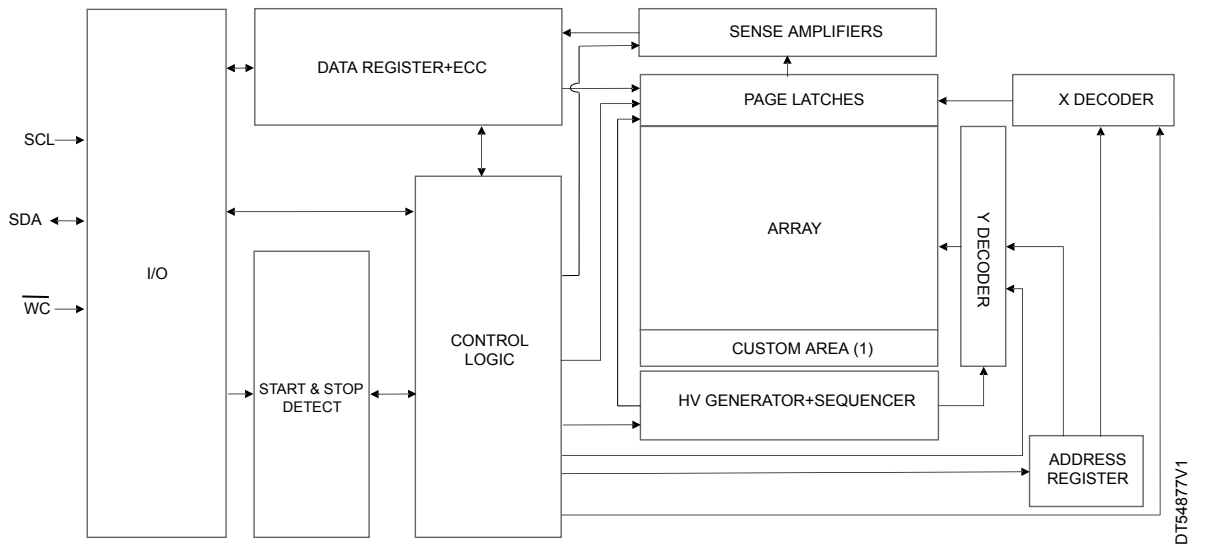

1. DTI, CDA, SWP registers and identification page.

## 4 Device features

The device type identifier 1011 must be used to address the DTI, SWP, CDA registers, and the identification page.

### 4.1 Device type identifier register (DTI)

The DTI is an 8-bit register permanently locked in read-only mode. This register is factory programmed with device type identifier bits (DTI3, DTI2, DTI1, and DTI0) set to 1011, and with device type identifier lock bit (DTIL) set to 1 to freeze definitively the register. DTI3, DTI2, DTI1, and DTI0 define the device type identifier address in the device select code. At power-up, the device loads the last configuration of DTI3, DTI2, DTI1, DTI0, and DTIL values.

This register is read by issuing the read device type identifier instruction. This instruction uses the same protocol and format as the random address read (from the memory array) except for the following differences (refer to Table 9, Table 10, and Table 11).

- Device type identifier = 1011
- MSB address bits A15, A14, and A13 must be equal to 111
- MSB address bits from A12 to A8 are don't care
- LSB address bits from A7 to A0 are don't care

The description of the device type identifier register is given in Table 2.

**Table 2. Device type identifier register**

bit 7	bit 6	bit5	bit4	bit3	bit2	bit1	bit0
DTI3=1	DTI2=0	DTI1=1	DTI0=1	X <sup>(1)</sup>	X	X	DTIL=1

1. X = Don't care bit. Read as 0.

*Note:* The factory default value is 10110001.

**Table 3. Device type identifier register description**

Bit	Function
Bits b7 to b4	<b>DTI3, DTI2, DTI1, DTI0:</b> Device type identifier bits. b7, b6, b5, b4 are used to configure the device type identifier of the device select code. <ul style="list-style-type: none"> <li>• (b7, b6, b5, b4) = (1, 0, 1, 1) the device type identifier is 1011 (factory default value)</li> </ul> Note: Bits b7 to b4 are frozen upon factory delivery.
Bits b3 to b1	Reserved bits. Read as 0. (b3, b2, b1) = (0, 0, 0)
Bit b0	<b>DTIL:</b> Device type identifier lock bit. b0 indicates that the DTI register status is in read-only mode. <ul style="list-style-type: none"> <li>• (b0) = (1) the device type identifier lock bit is equal to 1 (factory default value)</li> </ul> Note: Bit b0 is frozen upon factory delivery.

## 4.2 Configurable device address register (CDA)

The CDA is an 8-bit register allowing the user to define a configurable device address (C2 and C1) and a specific bit, named device address lock (DAL), to freeze definitively the configurable device address register. This register can be read and written by issuing the read or write configurable device address instruction. These instructions use the same protocol and format as the random address read or page write (from/into memory array) except for the following differences (refer to [Table 9](#), [Table 10](#), and [Table 11](#)):

- Device type identifier = 1011
- MSB address bits A15, A14, and A13 must be equal to 110
- MSB address bits from A12 to A8 are don't care
- LSB address bits from A7 to A0 are don't care

C2, C1, and DAL are defining the chip enable address in the device select code and the device address lock. These bits can be written and reconfigured with a write command. At power-up or after reprogramming, the device load the last configuration of C2, C1, and DAL values. To prevent unwanted change of configurable device address bits, the M24M01E-F proposes to protect the CDA register, permanently freezing it in read-only mode. The update of the CDA register is disabled (read-only) when the DAL bit is set to 1 (DAL = 1).

In the same way, the update of the CDA register is enabled when the DAL bit is set to 0 (DAL = 0). Sending more than one byte during a write configurable device address command aborts the write cycle (CDA register content does not change).

- Note:*
- *Updating the DAL bit from 0 to 1 is an irreversible action: the C2, C1, and DAL bits cannot be updated anymore.*
  - *If the write control input ( $\overline{WC}$ ) is driven high, or if the DAL bit is set to '1' the write configurable device address command is not executed, the accompanying data byte is not acknowledged, as shown in [Figure 7](#), and the write cycle does not start.*

The description of the configurable device address register is given in [Table 4](#).

**Table 4. Configurable device address register**

bit 7	bit 6	bit 5	bit 4	bit 3	bit 2	bit 1	bit 0
X <sup>(1)</sup>	X	X	X	C2	C1	X	DAL

1. X = Don't care bits. Read as 0.

- Note:* The factory default value is 00000000.  
 For devices delivered with preprogrammed device address:

- The default value of C2 and C1 are given in [Table 6](#). *Preprogrammed device address.*
- DAL is set to 1

**Table 5. Configurable device address register description**

Bit	Function
Bits b7 to b4 and b1	Don't care bits. Read as 0. (b7, b6, b5, b4, b1) = (0,0,0,0,0)
Bits b3 to b2	<b>C2, C1:</b> Configurable device address bits. b3, b2 are used to configure up to four possibilities of chip enable address: <ul style="list-style-type: none"> <li>• (b3, b2) = (0, 0): the chip enable address is 00 (factory delivery value)</li> <li>• (b3, b2) = (0, 1): the chip enable address is 01</li> <li>• (b3, b2) = (1,0): the chip enable address is 10</li> <li>• (b3, b2) = (1, 1): the chip enable address is 11</li> </ul>
Bit b0	<b>DAL:</b> Device address lock bit. b0 locks the CDA register in read-only mode: <ul style="list-style-type: none"> <li>• b0 = 0: bits b3, b2, and b0 can be modified</li> <li>• b0 = 1: bits b3, b2, and b0 cannot be modified and therefore the CDA register is frozen</li> </ul> Note: Bits b3, b2, and b0 can be updated (if b0 = 0) in the same write instruction. Setting b0 from 0 to 1 is an irreversible action.

In the case of M24M01E-F is delivered with the preprogrammed device address, the configurable device address register is locked at factory delivery and can only be read. The C2 and C1 bits are set as specified in [Table 6. Preprogrammed device address](#), and the DAL bit is set to 1.

The corresponding commercial product number with the preprogrammed device address is given in [Table 6. Preprogrammed device address](#).

**Table 6. Preprogrammed device address**

Commercial product number	Device address		Availability
	C2	C1	
M24M01E-Fxx6T1	0	1	Yes
M24M01E-Fxx6T2	1	0	On demand
M24M01E-Fxx6T3	1	1	On demand

1. 'xx' in the part number varies by package.

### 4.3 Software write protection register (SWP)

The SWP is a nonvolatile 8-bit register that allows the user to protect a specific area of the memory against the write instruction. The SWP offers four nonvolatile bits to configure by the user:

- Two bits for setting the size of the write-protected memory, identified as block protection bits (BP0, BP1)
- One bit to enable or disable the write protection of the desired area, identified as write protect activation bit (WPA)
- One bit to definitively freeze the SWP in read-only mode, identified as write protection lock bit (WPL)

This register can be read and written by issuing the read or write software write protection register instructions. These instructions use the same protocol and format as the random address read or page write (from/into memory array) except for the following differences (refer to [Table 9](#), [Table 10](#), and [Table 11](#)):

- Device type identifier = 1011
- MSB address bits A15, A14, and A13 must be equal to 101
- MSB address bits from A12 to A8 are don't care
- LSB address bits from A7 to A0 are don't care

BP1 and BP0 are the block protection bits. WPL is the write protect lock bit and WPA is the write protect activation bit. These bits can be written and reconfigured with a write command. At power-up, the device loads the last configuration of the SWP register value.

The user can update the SWP register as often as the WPL bit stays at 0. Writing more than one byte discard the write cycle (software write protection register content is not changed).

To prevent unwanted change of software write-protection register bits, the M24M01E-F proposes to protect the SWP register, freezing it permanently in read-only mode. The update of the SWP register is disabled (read-only) when the WPL bit is set to 1 (WPL = 1). In the same way, the update of the SWP register is enabled when the WPL bit is set to 0 (WPL = 0).

When WPL is set to 1, and in the case of writing to the software write protection register, the device select and address bytes are acknowledged, but the data byte is not acknowledged and the write cycle does not start.

- Note:*
- *Updating the WPL bit from 0 to 1 is an irreversible action: the WPA, BP1, BP0, and WPL bits cannot be updated any more*
  - *If the write control input ( $\overline{WC}$ ) is driven high or if the WPL bit is set to 1, the write command on the software write protection register is not executed and the accompanying data byte is not acknowledged, as shown in [Figure 11](#)*

The description of the software write protection register is given in the following table:

**Table 7. Software write protection register values**

bit 7	bit 6	bit 5	bit 4	bit 3	bit 2	bit 1	bit 0
X <sup>(1)</sup>	X	X	X	WPA	BP1	BP0	WPL

1. X = Don't care bits. Read as 0.

Note: The factory default value is 00000000.

**Table 8. Software write protection register description**

Bit	Function
Bits b7 to b4	<ul style="list-style-type: none"> <li>Don't care bits. Read as 0. (b7, b6, b5, b4) = (0, 0, 0, 0)</li> </ul>
Bits b3	<p><b>WPA:</b> Write protect activation bit.</p> <p>b3 enables or disables the write protection:</p> <ul style="list-style-type: none"> <li>b3 = 0: no write protection. The whole memory can be written.</li> <li>b3 = 1: write protection active. The memory block is protected according to the BP bits setting.</li> </ul>
Bits b2 to b1	<p><b>BP1, BP0:</b> block protection bits</p> <p>b2 and b1 define the size of the memory block to be protected against write instruction:</p> <ul style="list-style-type: none"> <li>(b2, b1) = (0, 0): the upper quarter of the memory is write-protected</li> <li>(b2, b1) = (0, 1): the upper half of the memory is write protected</li> <li>(b2, b1) = (1, 0): the upper ¾ of the memory is write protected</li> <li>(b2, b1) = (1, 1): the whole memory is write protected</li> </ul>
Bit b0	<p><b>WPL:</b> write protection lock bit</p> <p>b0 locks the write protection register value.</p> <ul style="list-style-type: none"> <li>b0 = 0: bits [b3: b0] can be modified</li> <li>b0 = 1: bits [b3: b0] cannot be modified and the write protection register is frozen.</li> </ul> <p>Note: bits b3 to b0 can be updated (if b0 = 0) in the same write instruction. Setting b0 from 0 to 1 is an irreversible action.</p>

## 4.4 Identification page

The identification page (256 bytes) is an additional page, which can be read or written and (later) permanently locked in read-only mode. It is read or written by issuing the read or write identification page instruction. These instructions use the same protocol and format as the random address read or page write (from/into memory array) except for the following differences (refer to [Table 9](#), [Table 10](#) and [Table 11](#)):

- Device type identifier = 1011
- MSB address bits A15, A14, and A13 must be equal to 000
- MSB address bits from A12 to A8 are don't care
- LSB address bits from A7 to A0 define the byte address inside the identification page

If the identification page is locked, the data bytes transferred during the write identification page instruction are not acknowledged (NO ACK).

The identification page is filled with all bytes written to FFh.

## 5 Device operation

The device supports the I<sup>2</sup>C protocol summarized in Figure 5. Any device that sends data onto the bus is defined as a transmitter, and any device that reads the data is defined as a receiver. The device that controls the data transfer is known as the bus controller, and the other as the target device. A data transfer can only be initiated by the bus controller, which also provides the serial clock for synchronization. The device is always a target in all communications.

Figure 5. I<sup>2</sup>C bus protocol

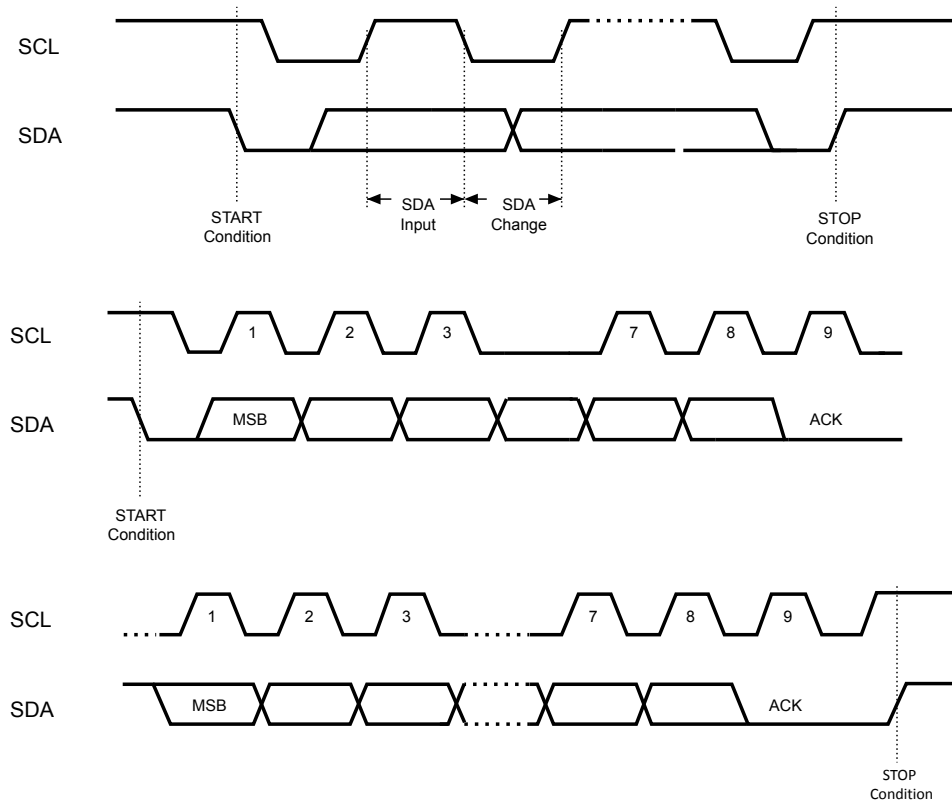

DT50012V1

### 5.1 Start condition

A start condition is identified by a falling edge of serial data (SDA) while the serial clock (SCL) is stable in the high state. This condition must precede any data transfer instruction. The device continuously monitors the SDA and SCL for a start signal, except during a write cycle.

### 5.2 Stop condition

The stop condition is identified by a rising edge of serial data (SDA) while the serial clock (SCL) is stable in the high state. This condition terminates the communication between the device and the bus controller. A read instruction followed by NO ACK can be followed by a stop condition to force the device into standby mode. A stop condition at the end of a write instruction triggers the internal write cycle.

### 5.3 Data input

During data input, the device samples the serial data (SDA) on the rising edge of the serial clock (SCL). For proper device operation, the SDA must be stable during the rising edge of the SCL, and the SDA signal must change only when the SCL is driven low.

### 5.4 Acknowledge bit (ACK)

The acknowledge bit is used to indicate a successful byte transfer. The bus transmitter, whether a bus controller or target device, releases serial data (SDA) after sending eight bits of data. During the ninth clock pulse period, the receiver pulls SDA low to acknowledge the receipt of the eight data bits.

## 5.5 Device addressing

To start communication between the bus controller and the target device, the bus controller must initiate a Start condition. Following this and unless the product is delivered with the preprogrammed device address, the bus controller sends the device select code and byte address as specified in [Table 9](#), [Table 10](#), and [Table 11](#).

When the device select code is received, the device responds only if the bits b3, and b2 values match the values of the C2 and C1 bits programmed in the configurable device address register.

If a match occurs, the corresponding device gives an acknowledgment on serial data (SDA) during the ninth bit time. If the device does not acknowledge the device select code, the device deselects itself from the bus, and goes into Standby mode (therefore it does not acknowledge the device select code).

The eighth bit is the read/write bit (RW). This bit is set to 1 for read and 0 for write operations.

The 128 Kbytes (1 Mbit) are addressed with 17 address bits, the 16 lower address bits being defined by the two address bytes and the most significant address bit (A16) being included in the device select code (see [Table 9](#)).

**Table 9. Device select code**

Features	Device type identifier bits				Chip enable address bits <sup>(1)</sup>		Address bit	R $\bar{W}$
	Bit 7 (MSB) <sup>(2)</sup>	Bit 6	Bit 5	Bit 4	Bit 3	Bit 2	Bit 1	Bit 0 (LSB)
Memory	1	0	1	0	C2	C1	A16	R $\bar{W}$
Device type identifier	1	0	1	1	C2	C1	X <sup>(3)</sup>	R $\bar{W}$
Configurable device address	1	0	1	1	C2	C1	X	R $\bar{W}$
Software write protection	1	0	1	1	C2	C1	X	R $\bar{W}$
Identification page	1	0	1	1	C2	C1	X	R $\bar{W}$
Identification page lock	1	0	1	1	C2	C1	X	R $\bar{W}$

1. C1 and C2 are compared with the value read on bits b2 and b3 of the CDA register.

2. The most significant bit, b7, is sent first.

3. X = Don't care bit

**Table 10. First byte address**

Features	Bit 7 (MSB) <sup>(1)</sup>	Bit 6	Bit 5	Bit 4	Bit 3	Bit 2	Bit 1	Bit 0 (LSB)
Memory	A15	A14	A13	A12	A11	A10	A9	A8
Device type identifier	1	1	1	X <sup>(2)</sup>	X	X	X	X
Configurable device address	1	1	0	X	X	X	X	X
Software write protection	1	0	1	X	X	X	X	X
Identification page	0	0	0	X	X	X	X	X
Identification page lock	0	1	1	X	X	X	X	X

1. The most significant bit, b7, is sent first.

2. X = Don't care bit

**Table 11. Second byte address**

Features	Bit 7 (MSB) <sup>(1)</sup>	Bit 6	Bit 5	Bit 4	Bit 3	Bit 2	Bit 1	Bit 0 (LSB)
Memory	A7	A6	A5	A4	A3	A2	A1	A0
Device type identifier	X <sup>(2)</sup>	X	X	X	X	X	X	X
Configurable device address	X	X	X	X	X	X	X	X
Software write protection	X	X	X	X	X	X	X	X
Identification page	A7	A6	A5	A4	A3	A2	A1	A0
Identification page lock	X	X	X	X	X	X	X	X

1. The most significant bit, b7, is sent first.

2. X = Don't care bit

## 6 Instructions

### 6.1 Write operations on memory array

Following a start condition the bus controller sends a device select code with the R/W bit ( $\overline{RW}$ ) reset to 0. The device acknowledges this, as shown in [Figure 6](#), and waits for two address bytes. The device responds to each address byte with an acknowledge bit, and then waits for the data byte. See in [Table 9](#), [Table 10](#), and [Table 11](#) how to address the memory array.

The 128 Kbytes (1 Mb) are addressed with 17 address bits, the 16 lower address bits being defined by the two address bytes and the most significant address bit (A16) being included in the device select code (see [Table 9](#)).

When the bus controller generates a stop condition immediately after a data byte ACK bit (in the tenth bit time slot), either at the end of a byte write or a page write, the internal write cycle  $t_W$  is triggered. A stop condition at any other time slot does not trigger the internal write cycle.

After the stop condition and the successful completion of an internal write cycle ( $t_W$ ), the device internal address counter is automatically incremented to point to the next byte after the last modified byte.

During the internal write cycle, serial data (SDA) is disabled internally, and the device does not respond to any requests.

If the addressed area is write protected by software through the SWP setting or hard protected through  $\overline{WC}$  pin driven high, the write instruction is not executed and the accompanying data bytes are not acknowledged, as shown in [Figure 7](#).

### 6.1.1 Byte write

After the device select code and the address bytes, the bus controller sends one data byte. If the addressed location is write-protected, through the SWP setting or through the  $\overline{WC}$  pin being driven high, the device replies with NO ACK, and the location is not modified. If the addressed location is not write-protected, the device replies with ACK. The bus controller terminates the transfer by generating a stop condition, as shown in Figure 6.

Figure 6. Write mode sequences without write protection (data write enabled)

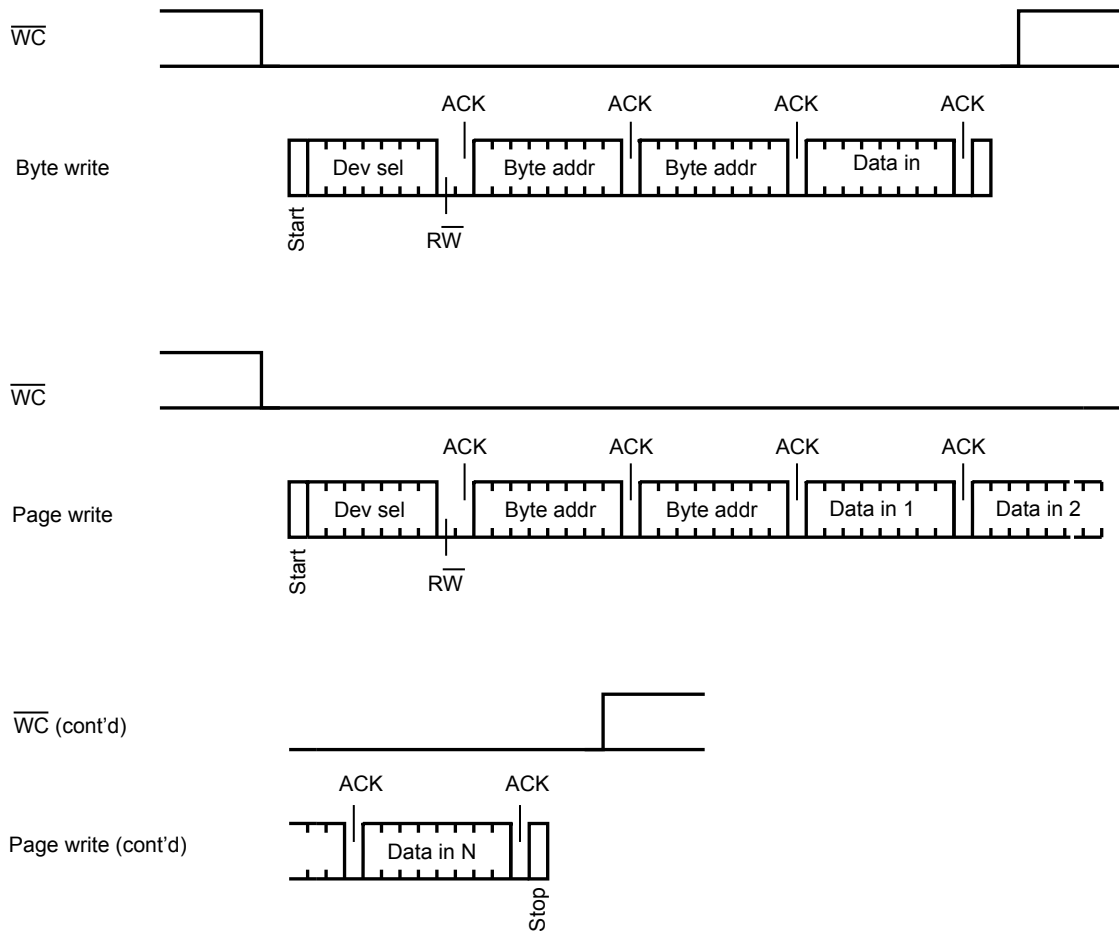

### 6.1.2 Page write

The page write mode allows up to 256-byte to be written in a single write cycle, provided that they are all located in the same page in the memory: that is, the most significant memory address bits, from A16 to A8, are the same. If more bytes are sent than fit up to the end of the page, a roll-over occurs, that is, the bytes exceeding the page end are written on the same page, from location 0.

The bus controller sends from 1 to 256 bytes of data, each of which is acknowledged by the device if the addressed bytes are not write-protected through the SWP setting or the WC pin (driven low). In the opposite case, when the addressed bytes are write-protected by SWP settings or WC pin (driven high), the contents of the addressed memory location are not modified, and each data byte is followed by a NO ACK, as shown in Figure 7. After each transferred byte, the internal page address counter is incremented.

The transfer is terminated by the bus controller generating a stop condition.

Figure 7. Write mode sequences with write protection (data write inhibited)

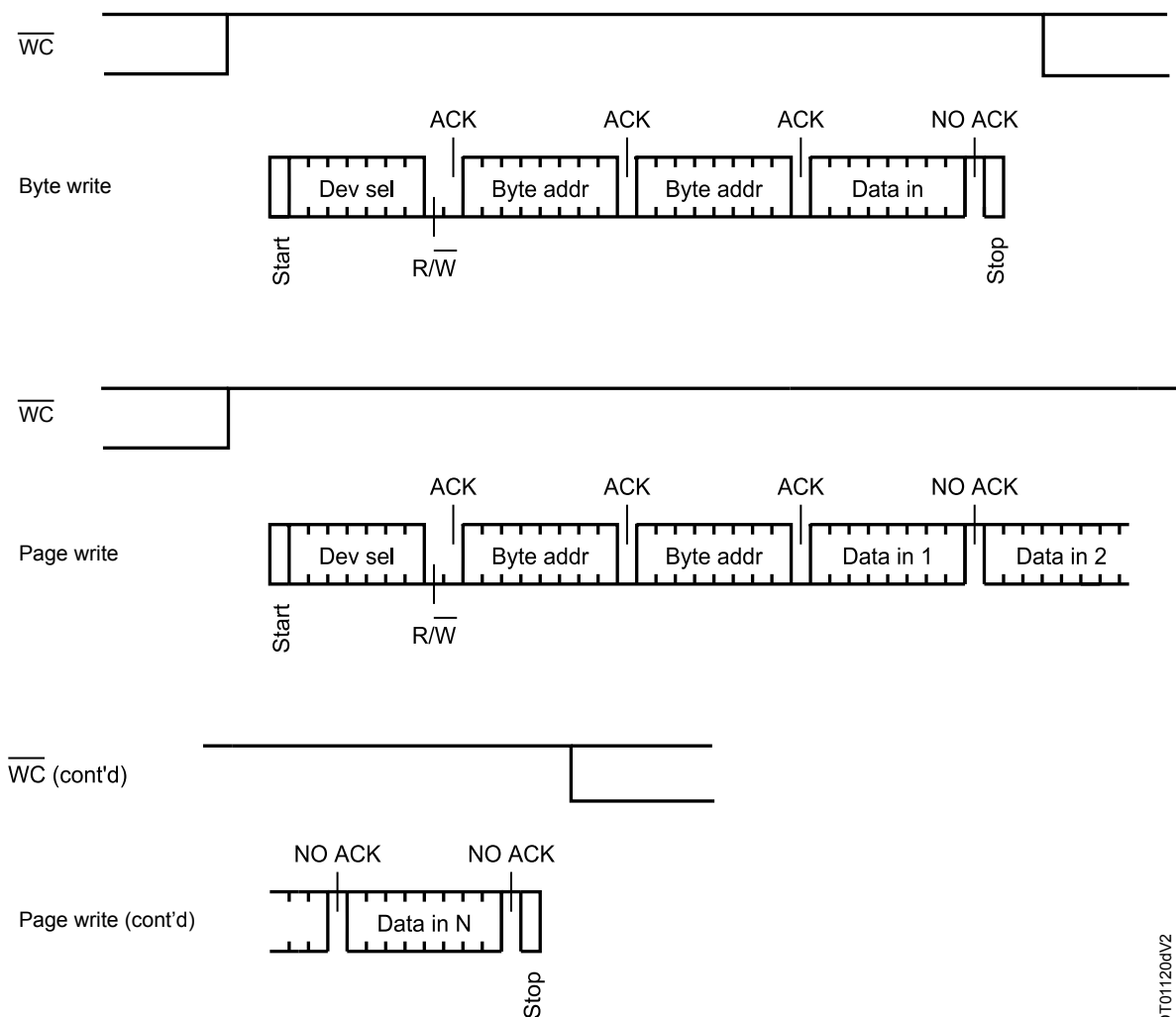

DT01120dV2

## 6.2 Write operations on features

### 6.2.1 Write operation on DTI register

Write operations on device type identifier (DTI) register are not allowed.  
The register is delivered locked in read-only.

### 6.2.2 Write operation on CDA register

Write operations on a configurable device address register are performed according to the state of the device address lock bit (DAL) or the status of  $\overline{WC}$  line.

If the configurable device address register is write protected by software with  $DAL = 1$  or hard protected with  $\overline{WC}$  line driven high, the write operation on this register is not executed and the accompanying data byte is not acknowledged as shown in Figure 9.

Following a start condition the bus controller sends a device select code with the R/W bit ( $\overline{RW}$ ) set to 0. The device acknowledges this, as shown in Figure 8, and waits for the address bytes where the register is located. The device responds to each address byte with an acknowledge bit, and then waits for the data byte. See in Table 9, Table 10, and Table 11 how to address the configurable device address register.

When the bus controller generates a stop condition immediately after the data byte ACK bit (in the tenth bit time slot), the internal write cycle  $t_W$  is triggered. A stop condition at any other time slot does not trigger the internal write cycle.

During the internal write cycle, serial data (SDA) is disabled internally, and the device does not respond to any requests (NO ACK).

If the two-bit C2 and C1 have been reconfigured with a correct write command, the device acknowledges if the chip enable address of the device select code is equal to the new values of C2 and C1, otherwise NO ACK.

Sending more than one byte aborts the write cycle (configurable device address content does not change). Bits (C2, C1 + DAL) can be updated ( $DAL = 0$  to 1) in the same program instruction.

Figure 8. Write CDA register (data write enabled)

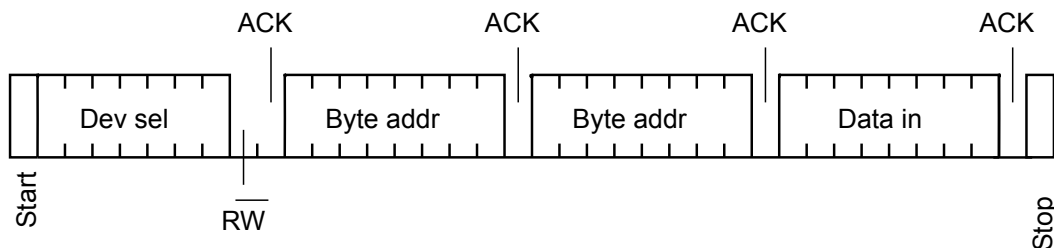

DT67285V1

Figure 9. Write CDA register (data write inhibited by software or hardware)

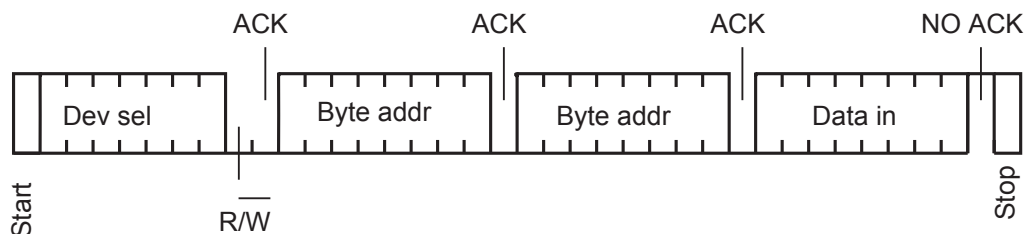

DT67286V1

### 6.2.3 Write operation on SWP register

Write operations on SWP register are performed according to the state of the write protect lock bit (WPL) or to the status of the  $\overline{WC}$  line.

Following a start condition the bus controller sends a device select code with the R/W bit ( $\overline{RW}$ ) set to 0. The device acknowledges this, as shown in Figure 10, and waits for the address bytes where the SWP register is located. The device responds to each address byte with an acknowledge bit, and then waits for the data byte. See in Table 9, Table 10, and Table 11 how to address the software write protection register.

When the bus controller generates a stop condition immediately after the data byte ACK bit (in the tenth bit time slot), the internal write cycle  $t_{W}$  is triggered. A stop condition at any other time slot does not trigger the internal write cycle.

During the internal write cycle, serial data (SDA) is disabled internally, and the device does not respond to any requests (NO ACK).

Sending more than one byte aborts the write cycle (software write protection register content is not changed).

If the SWP register is already locked or hard write protected with  $\overline{WC}$  line driven high, the write operation is not executed and the accompanying data byte is not acknowledged as shown in Figure 11.

Figure 10. Write SWP register (data write enabled)

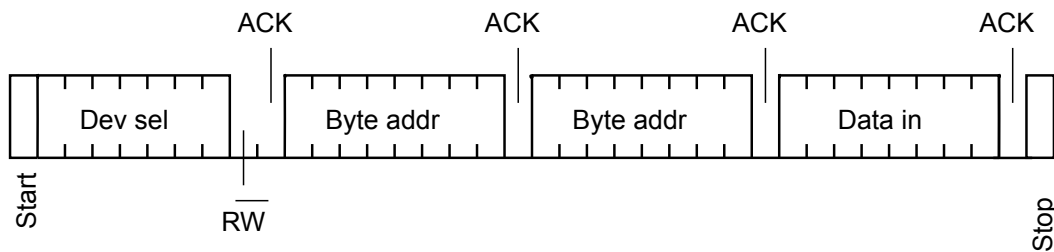

DT67285V1

Figure 11. Write SWP register (data write inhibited by software or hardware)

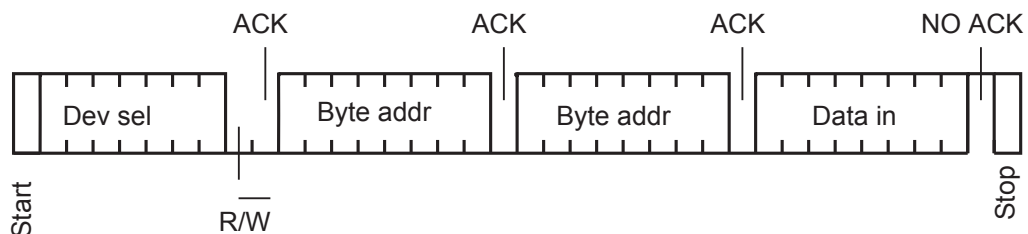

DT67286V1

### 6.2.4 Write operation on identification page

Write operations on the identification page are performed according to the state of the  $\overline{WC}$  line or to the lock/unlock status.

Following a start condition the bus controller sends a device select code with the R/W bit ( $\overline{RW}$ ) set to 0. The device acknowledges this, as shown in Figure 12, and waits for the address bytes where the identification page is located. The device responds to each address byte with an acknowledge bit, and then waits for the data byte. See in Table 9, Table 10, and Table 11 how to address the identification page.

When the bus controller generates a stop condition immediately after the data byte ACK bit (in the tenth bit time slot), the internal write cycle  $t_W$  is triggered. The device internal address counter is automatically incremented to point to the next byte after the last modified byte.

A stop condition at any other time slot does not trigger the internal write cycle.

During the internal write cycle, serial data (SDA) is disabled internally, and the device does not respond to any requests (NO ACK).

If the identification page is already locked in read-only mode (lock status) or hard write protected with  $\overline{WC}$  line driven high, the write operation on the identification page is not executed and the accompanying data bytes are not acknowledged as shown in Figure 13.

**Figure 12. Write identification page (page unlocked)**

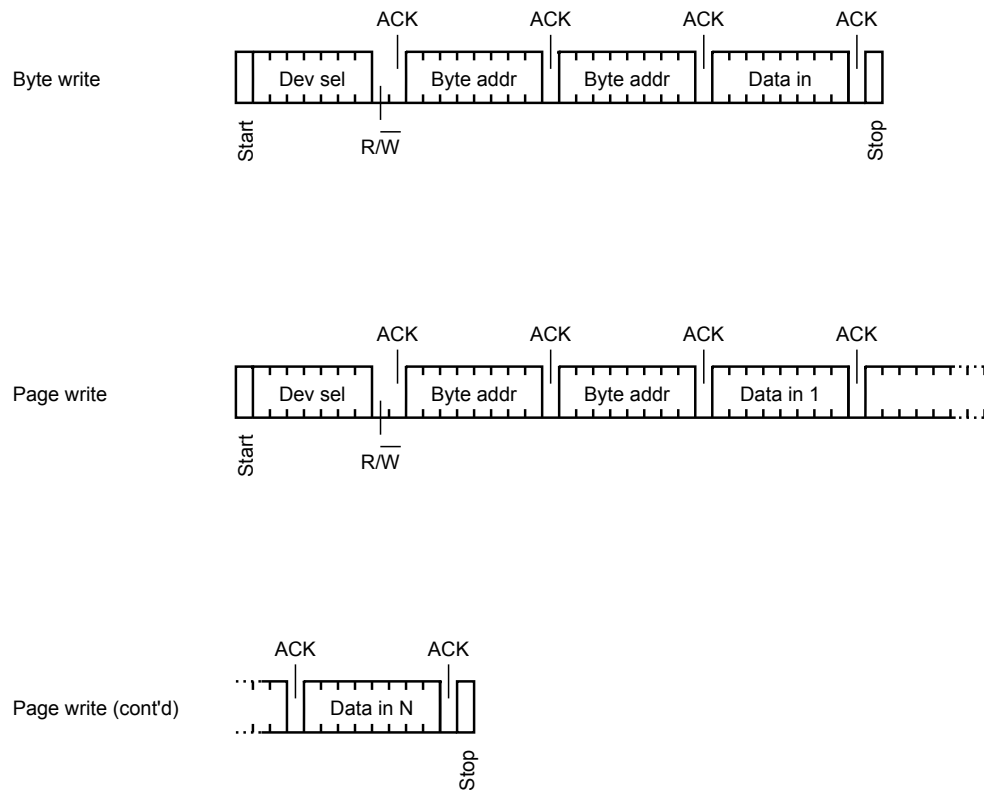

DT01106eV1

Figure 13. Write identification page (page locked or hard protected)

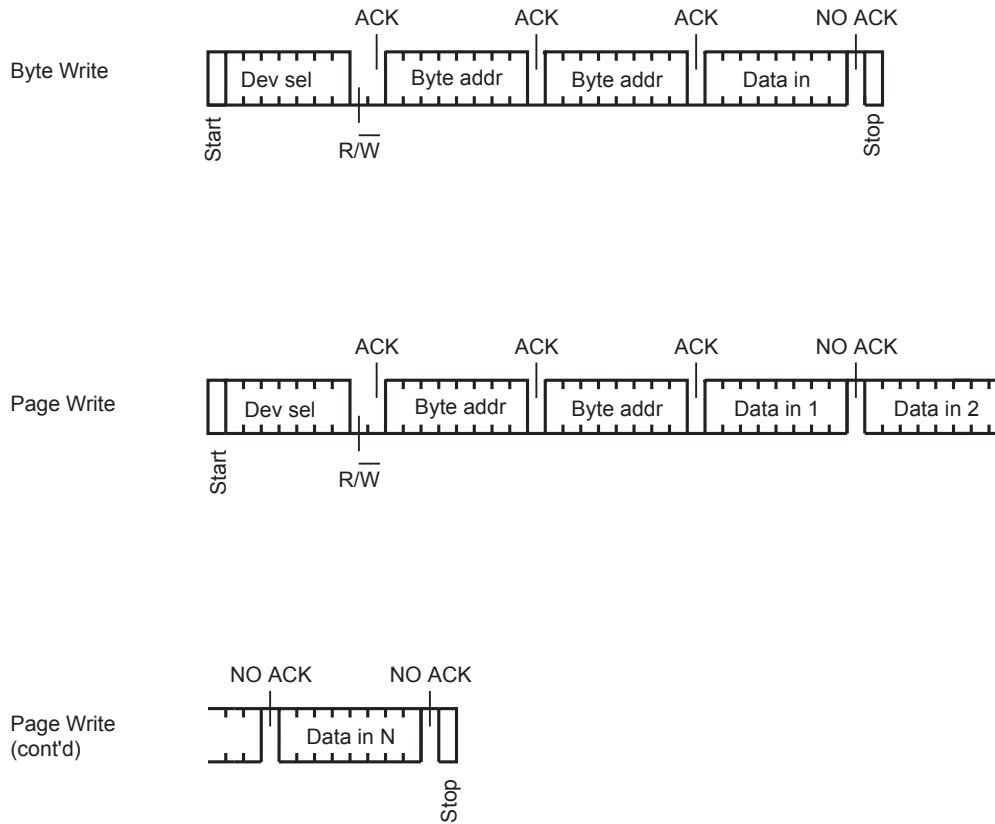

DT01120eV1

### 6.2.5 Lock operation on identification page

The lock identification page instruction (lock ID) permanently locks the identification page in read-only mode.

Following a start condition the bus controller sends a device select code with the R/W bit ( $\overline{RW}$ ) set to 0. The device acknowledges this, as shown in Figure 14, and waits for the address bytes where the identification page is located. The device responds to each address byte with an acknowledge bit, and then waits for a specific data byte value. See in Table 9, Table 10, and Table 11 how to address the identification page.

The data byte must be equal to the binary value xxxx xx1x, where x is don't care.

When the bus controller generates a stop condition immediately after the data byte ACK bit (in the tenth bit time slot), the internal write cycle  $t_W$  is triggered. A stop condition at any other time slot does not trigger the internal write cycle.

During the internal write cycle, serial data (SDA) is disabled internally, and the device does not respond to any requests (NO ACK).

If the identification page is already locked or hard write protected with  $\overline{WC}$  line driven high, the write operation is not executed and the accompanying data bytes are not acknowledged as shown in Figure 15.

Figure 14. Lock operation on identification page (unlocked or data write enabled)

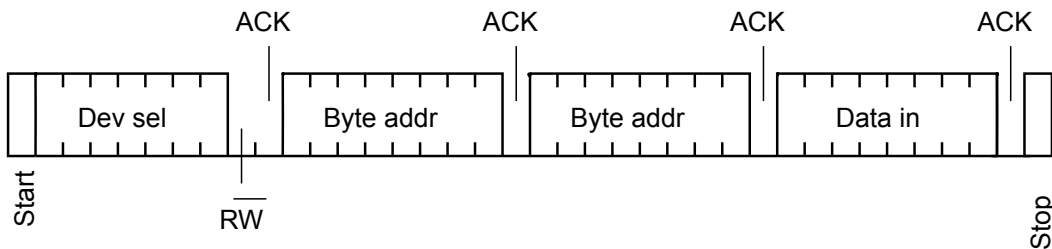

DT67285V1

Figure 15. Lock operation on identification page (already locked or data write inhibited by hardware)

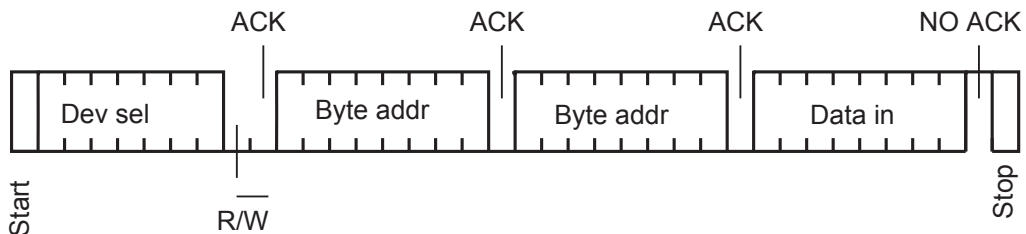

DT67286V1

### 6.2.6 Minimizing write delays by polling on ACK

During the internal write cycle, the device disconnects itself from the bus, and writes a copy of the data from its internal latches to the memory cells. The maximum write time ( $t_w$ ) is shown in Table 19. AC characteristics in Fast-mode and Table 20. AC characteristics in Fast-mode Plus, but the typical time is shorter. The bus controller can implement a polling sequence to utilize this feature.

The sequence, as shown in Figure 16, is:

- Initial condition: A write cycle is in progress.
- Step 1: The bus controller issues a Start condition followed by a device select code (the first byte of the new instruction).
- Step 2: If the device is busy with the internal write cycle, NO ACK is returned and the bus controller goes back to step 1. If the device has terminated the internal write cycle, it responds with an ACK, indicating that the device is ready to receive the second part of the instruction (the first byte of this instruction having been sent during step 1).

*Note:* When writing a command to the configurable device address register when C2 and C1 are reconfigured, the device returns ACK only if:

- Chip enable address of the device select code is equal to the new C2 and C1 values.
- An internal write cycle is completed (a new C2 and C1 values have been programmed in the chip enable register).

Figure 16. Write cycle polling flowchart using ACK

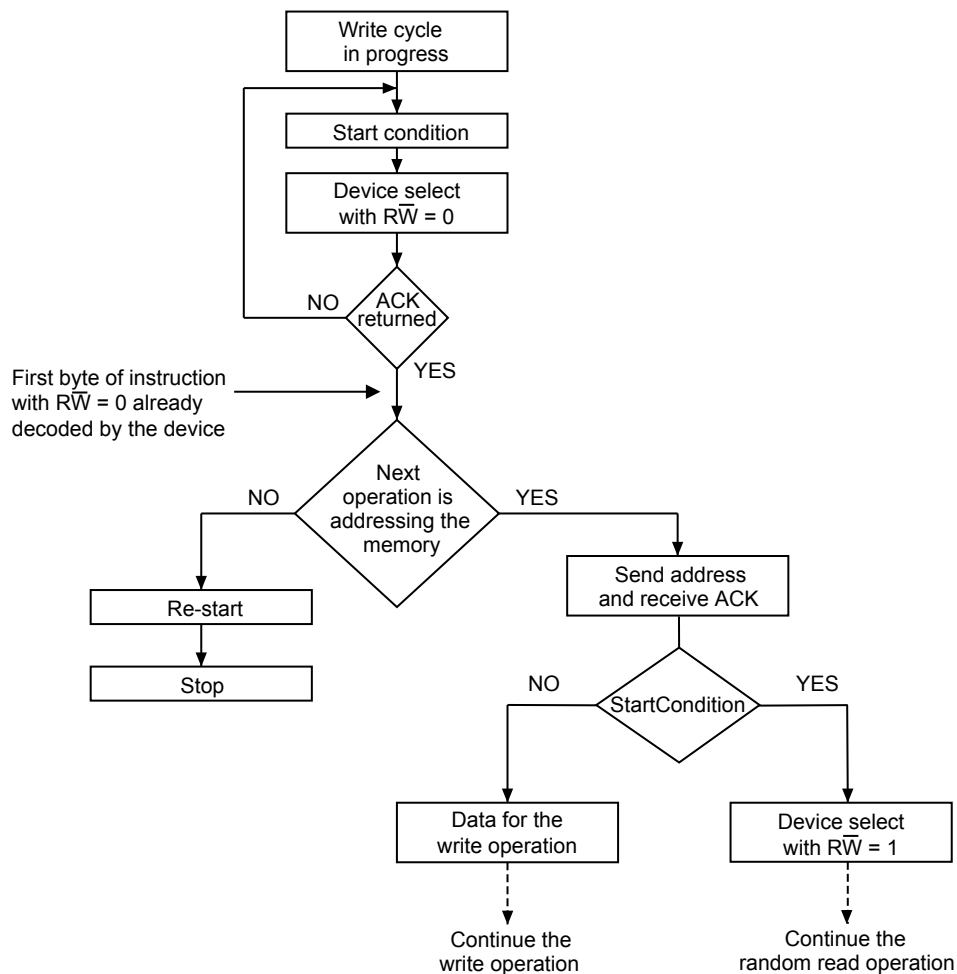

1. The seven most significant bits of the device select code of a random read (bottom right box in the figure) must be identical to the seven most significant bits of the device select code of the write (polling instruction in the figure).

### 6.3 ECC (error correction code) and write cycling

The error correction code (ECC) is an internal logic function, transparent for the I<sup>2</sup>C communication protocol.

The ECC logic is implemented on each group of four bytes (located at addresses  $[4*N, 4*N+1, 4*N+2, 4*N+3]$ , where N is an integer). Within a group, if a single bit happens to be erroneous during a read operation, the ECC detects and replaces it with the correct value. The read reliability is therefore much improved.

Even if the ECC function is performed on groups of four bytes, a single byte can be written/cycled independently. In this case, the ECC function also writes/cycles the three other bytes located in the same group. As a consequence, the maximum cycling budget is defined at group level and the cycling can be distributed over the four bytes of the group: the sum of the cycles seen by byte0, byte1, byte2, and byte3 of the same group must remain below the maximum value defined in [Table 16. Cycling performance by groups of four bytes](#).

## 6.4 Read operations on memory array

Following a start condition the bus controller sends a device select code with the R/W bit ( $\overline{RW}$ ) set to 0. The device acknowledges this and waits for the two-byte address. The device responds to each address byte with an acknowledge bit. Then, the bus controller sends another start condition, and repeats the device select code, with the R/W bit set to 1. The device acknowledges this, and outputs the contents of the data. See in [Table 9](#), [Table 10](#) and [Table 11](#) how to address the memory array.

After each byte read (data out), the device waits for an acknowledgment (data in) during the ninth bit time. If the bus controller does not acknowledge during this interval, the device terminates the data transfer and switches to its standby mode after a stop condition.

After the successful completion of a read operation, the internal address counter is incremented by one, to point to the next byte address.

**Figure 17. Read mode sequences**

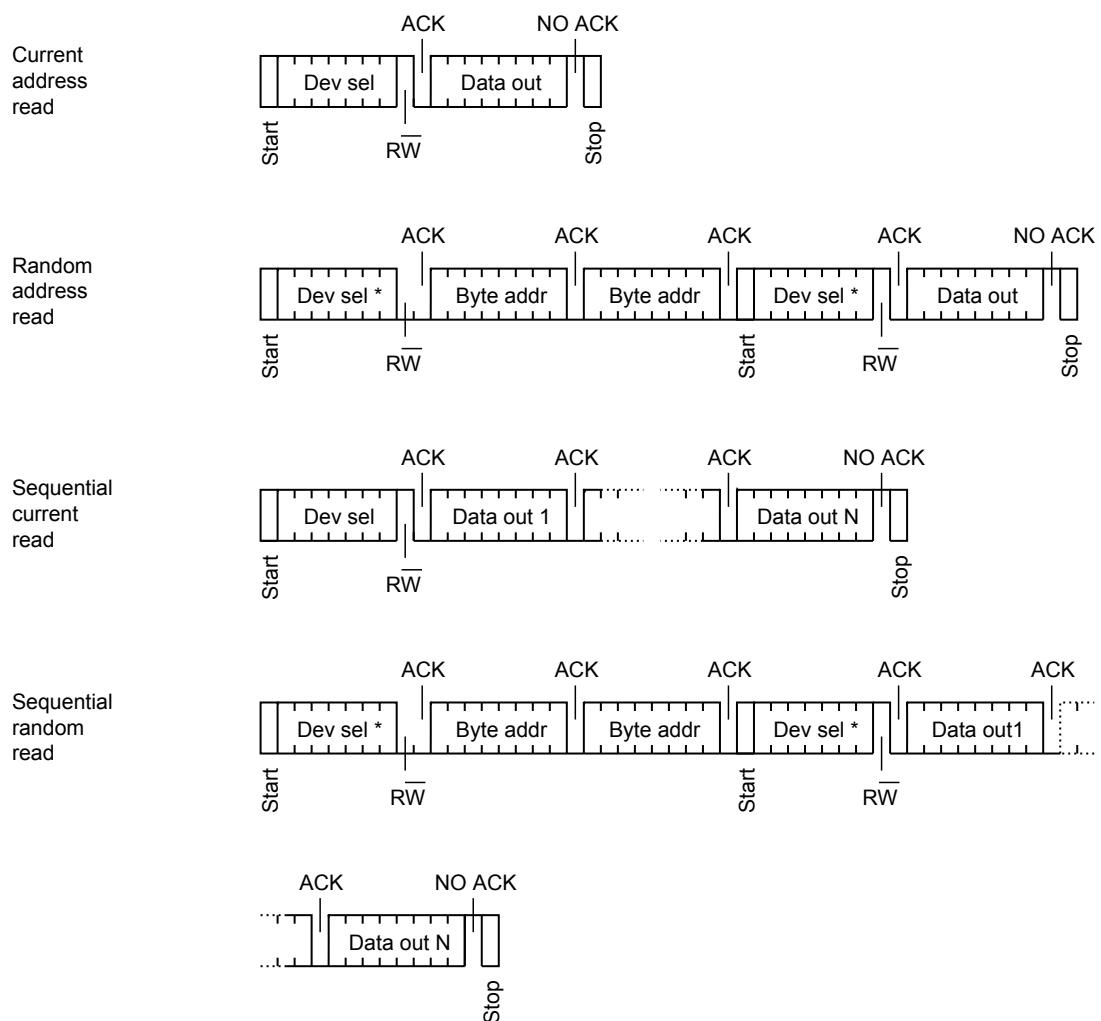

**Note:** \*: The seven most significant bits of the first device select code of a random read must be identical to the seven most significant bits of the device select code of the write.

#### 6.4.1 Random address read

A dummy write is first performed to load the address into this address counter (as shown in [Figure 17](#)) but without sending a stop condition. Then, the bus controller sends another start condition, and repeats the device select code, with the RW bit set to 1. The device acknowledges this, and outputs the contents of the addressed byte. The bus controller must not acknowledge the byte, and terminates the transfer with a stop condition.

#### 6.4.2 Current address read

For the current address read operation, following a start condition, the bus controller sends only a device select code with the RW bit set to 1. The device acknowledges this, and outputs the byte addressed by the internal address counter. The counter is then incremented. The bus controller terminates the transfer with a stop condition, as shown in [Figure 17](#), without acknowledging the byte.

*Note:* The address counter value is defined by instructions accessing either the memory, the registers, or the identification page. When accessing the registers or the identification page, the address counter value is loaded with the byte location, therefore the next current address read in the memory uses this new address counter value. When accessing the memory, it is safer to always use the random address read instruction (this instruction loads the address counter with the byte location to read in the memory, see [Random address read](#)) instead of the current address read instruction.

#### 6.4.3 Sequential read

This operation can be used after a current address read or a random address read. The bus controller does not acknowledge the data byte output, and sends additional clock pulses so that the device continues to output the next byte in sequence. To terminate the stream of bytes, the bus controller must not acknowledge the last byte, and must generate a stop condition, as shown in [Figure 17](#).

The output data comes from consecutive addresses, with the internal address counter automatically incremented after each byte output. After the last memory address, the address counter rolls-over, and the device continues to output data from the memory address 00h.

## 6.5 Read operations on features

Only the random address read or sequential random read commands are authorized to access the four additional features. The address counter contains meaningful address value only after these authorized commands have been performed.

### 6.5.1 Read operation on DTI register

Following a start condition the bus controller sends a device select code with the R/W bit ( $\overline{RW}$ ) set to 0. The device acknowledges this and waits for the address bytes where the DTI register is located. The device responds to each address byte with an acknowledge bit. Then, the bus controller sends another start condition, and repeats the device select code, with the  $\overline{RW}$  bit set to 1. The device acknowledges this, and outputs the contents of the DTI register. See in Table 9, Table 10, and Table 11 how to address the device type identifier register.

After the successful completion of a read device type identifier, the device internal address counter is not incremented by one, to point to the next byte address. Reading more than one byte with the sequential random read command loops on reading the device type identifier register value.

To terminate the stream of data byte, the bus controller must not acknowledge the byte, and must generate a stop condition, as shown in Figure 18.

The device type identifier register cannot be read while a write cycle ( $t_W$ ) is ongoing.

Figure 18. Random read DTI register

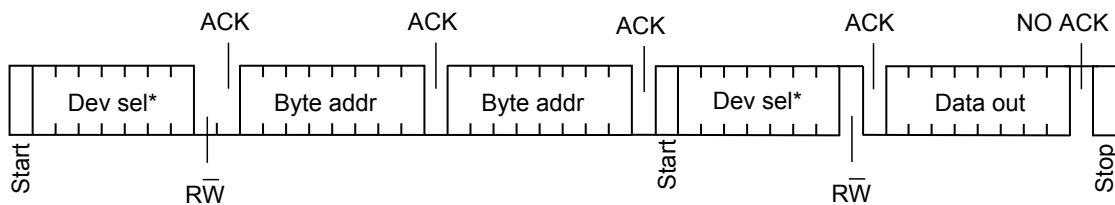

DT51972V1

\*: The seven most significant bits of the first device select code of a random read must be identical to the seven most significant bits of the device select code of the write.

### 6.5.2 Read operation on CDA register

Following a start condition the bus controller sends a device select code with the R/W bit ( $\overline{RW}$ ) set to 0. The device acknowledges this and waits for the address bytes where the CDA register is located. The device responds to each address byte with an acknowledge bit. Then, the bus controller sends another start condition, and repeats the device select code, with the  $\overline{RW}$  bit set to 1. The device acknowledges this, and outputs the contents of the CDA register. See in Table 9, Table 10, and Table 11 how to address the configurable device address register.

After the successful completion of a read configurable device address, the device internal address counter is not incremented by one, to point to the next byte address. Reading more than one byte with the sequential random read command loops on reading the configurable device address register value.

To terminate the stream of data byte, the bus controller must not acknowledge the byte, and must generate a stop condition, as shown in Figure 19.

The configurable device address register cannot be read while a write cycle ( $t_W$ ) is ongoing.

The configurable device address bits (C2 and C1) values can be checked by sending the device select code.

- If the chip enable address b3 and b2 sent in the device select code is matching with the C2 and C1 values, the device sends an ACK.
- Otherwise, the device answers no ACK.

Figure 19. Random read CDA register

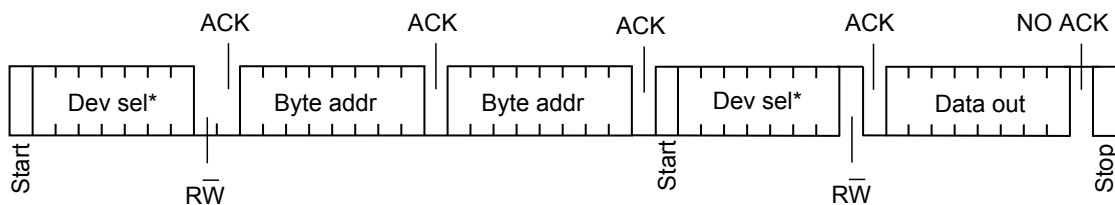

DT51972V1

\*: The seven most significant bits of the first device select code of a random read must be identical to the seven most significant bits of the device select code of the write.

### 6.5.3 Read operation on SWP register

Following a start condition the bus controller sends a device select code with the R/W bit ( $\overline{RW}$ ) set to 0. The device acknowledges this and waits for the address bytes where the SWP register is located. The device responds to each address byte with an acknowledge bit. Then, the bus controller sends another start condition, and repeats the device select code, with the  $\overline{RW}$  bit set to 1. The device acknowledges this, and outputs the contents of the SWP register. See in Table 9, Table 10, and Table 11 how to address the software write protection register.

After the successful completion of a read operation on SWP, the device internal address counter is not incremented by one, to point to the next byte address. Reading more than one-byte with the sequential random read command loops on reading the SWP register value.

To terminate the stream of data byte, the bus controller must not acknowledge the byte, and must generate a stop condition, as shown in Figure 20.

The SWP register cannot be read while a write cycle ( $t_W$ ) is ongoing.

Figure 20. Random read SWP register

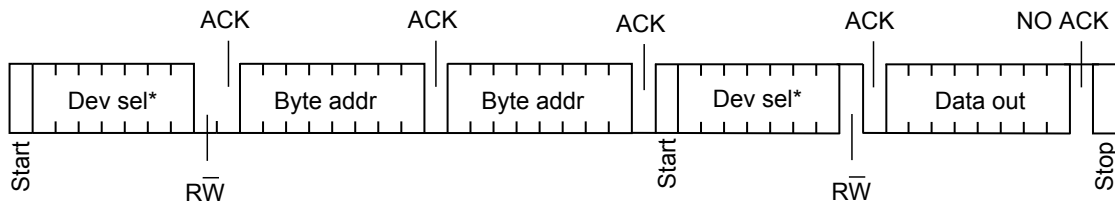

DT51972V1

\*: The seven most significant bits of the first device select code of a random read must be identical to the seven most significant bits of the device select code of the write.

### 6.5.4 Read operation on identification page

Following a start condition the bus controller sends a device select code with the R/W bit ( $\overline{RW}$ ) set to 0. The device acknowledges this and waits for the address bytes where the identification page is located. The device responds to each address byte with an acknowledge bit. Then, the bus controller sends another start condition, and repeats the device select code, with the  $\overline{RW}$  bit set to 1. The device acknowledges this, and outputs the contents of the identification page. See in Table 9, Table 10, and Table 11 how to address the identification page. After each byte read (data out), the device waits for an acknowledgment (data in) during the ninth bit time.

The output data of the identification page comes from consecutive addresses, with the internal address counter automatically incremented after each byte output. After the last identification page address (FFh), the address counter rolls-over, and the device continues to output data from identification page address 00h.

To terminate the stream of data byte, the bus controller must not acknowledge the byte, and must generate a stop condition, as shown in Figure 21.

If the bus controller does not acknowledge during this ninth time, the device terminates the data transfer as shown in Figure 21 and switches to its standby mode.

Figure 21. Random read identification page

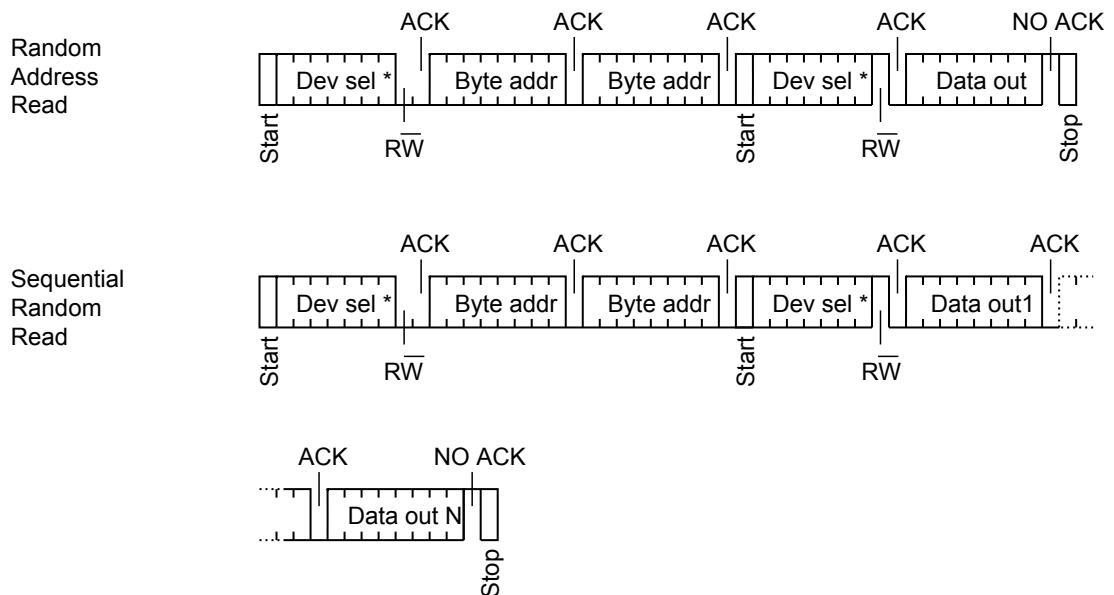

\*: The seven most significant bits of the first device select code of a random read must be identical to the seven most significant bits of the device select code of the write.

### 6.5.5 Read lock status on identification page

The lock/unlock status of the identification page can be checked by transmitting a specific truncated command.

Following a start condition the bus controller sends a device select code with the R/W bit ( $\overline{RW}$ ) set to 0. The device acknowledges this and waits for the address bytes where the identification page is located. The device responds to each address byte with an acknowledge bit, and then waits for the data byte. See in Table 9, Table 10 and Table 11 how to address the identification page.

The device returns an acknowledge bit after the data byte if the identification page is unlocked (unlock status) as shown in Figure 22, otherwise a NO ACK bit as shown in Figure 23, if the identification page is locked (lock status).

Right after this, it is recommended to transmit to the device a start condition followed by a stop condition, so that:

- Start: the truncated command is not executed because the start condition resets the device internal logic
- Stop: the device is then set back into standby mode by the stop condition

Figure 22. Read lock status (identification page unlocked)

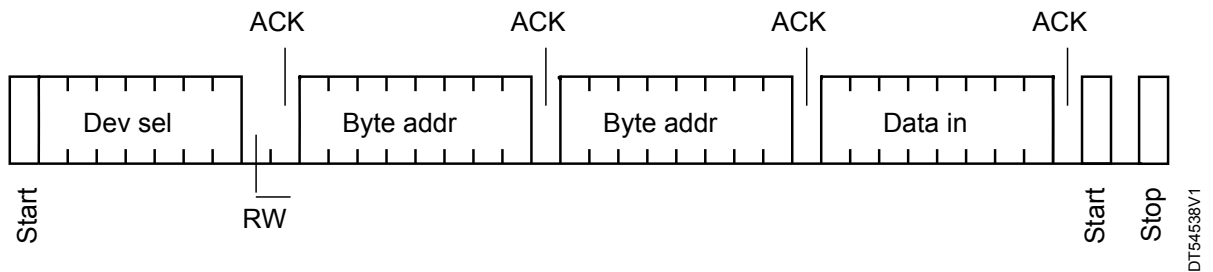
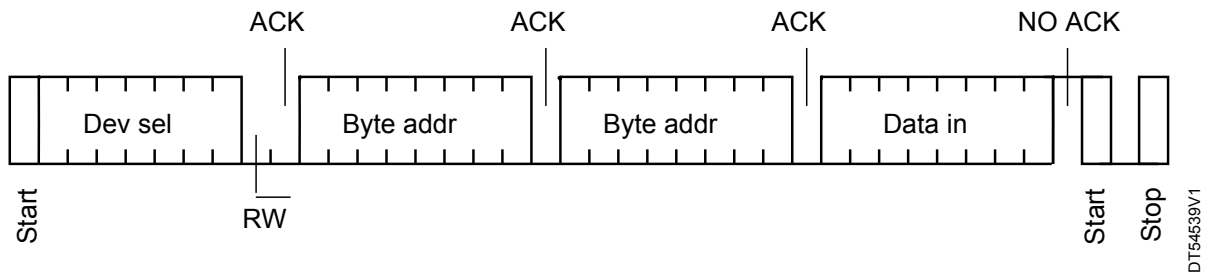

Figure 23. Read lock status (identification page locked)



## 7 Initial delivery state

At factory delivery unless a specific device address has been preprogrammed, the device is delivered with:

- All the memory array bits set to 1 (each byte contains FFh)
- The DTI register locked and set to 10110001 (B1h)
- The CDA register set to 00000000 (00h)
- The SWP register set to 00000000 (00h)
- All the identification page bits set to 1 (each byte contains FFh)

## 8 Maximum ratings

Stressing the device outside the ratings listed in Table 12 may permanently damage it. These are stress ratings only, and operation of the device at these, or any other conditions outside those indicated in the operating sections of this specification, is not implied. Exposure to absolute maximum rating conditions for extended periods may affect device reliability.

**Table 12. Absolute maximum ratings**

Symbol	Parameter	Min.	Max.	Unit
-	Ambient operating temperature	-40	130	°C
T <sub>STG</sub>	Storage temperature	-65	150	°C
T <sub>LEAD</sub>	Lead temperature during soldering	see note <sup>(1)</sup>		°C
I <sub>OL</sub>	DC output current (SDA = 0)	-	5	mA
V <sub>IO</sub>	Input or output range	-0.50	6.5	V
V <sub>CC</sub>	Supply voltage	-0.50	6.5	V
V <sub>ESD</sub>	Electrostatic pulse (human body model) <sup>(2)</sup>	-	4000	V

1. Compliant with JEDEC Std J-STD-020 (for small body, Sn-Pb or Pb-free assembly), the ST ECOPACK 7191395 specification, and the European directive on restrictions of hazardous substances (RoHS directive 2011/65/EU of July 2011).
2. Positive and negative pulses applied on different combinations of pin connections, according to ANSI/ESDA/JEDEC JS-001 (C1=100 pF, R1=1500 Ω, R2 = 500 Ω).

## 9 DC and AC parameters

This section summarizes the operating and measurement conditions, and the DC and AC characteristics.

**Table 13. Operating conditions**

Symbol	Parameter	Min.	Max.	Unit
$V_{CC}$	Supply voltage	1.6	5.5	V
$T_A$	Ambient operating temperature	-40	85	°C
$f_C$	Operating clock frequency	-	1	MHz

**Table 14. AC measurement conditions**

Symbol	Parameter	Min.	Max.	Unit
$C_{bus}$	Load capacitance	-	100	pF
-	SCL input rise/fall time, SDA input fall time	-	50	ns
-	Input levels	0.2 $V_{CC}$ to 0.8 $V_{CC}$		V
-	Input and output timing reference levels	0.3 $V_{CC}$ to 0.7 $V_{CC}$		V

**Figure 24. AC measurement I/O waveform**

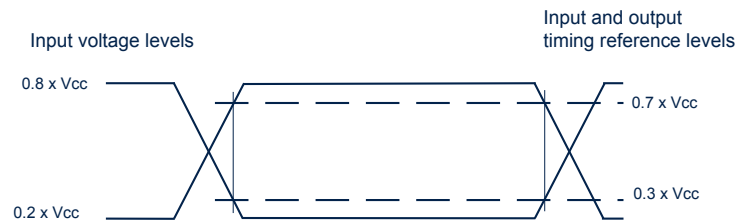

DT54878V1

**Table 15. Input parameters**

Symbol	Parameter	Test condition	Min.	Max.	Unit
$C_{IN}^{(1)}$	Input capacitance (SDA)	-	-	8	pF
$C_{IN}^{(1)}$	Input capacitance (other pins)	-	-	6	pF
$Z_L^{(2)}$	Input impedance ( $\overline{WC}$ ) <sup>(3)</sup>	$V_{IN} < 0.3 V_{CC}$	30	-	kΩ
$Z_H^{(2)}$		$V_{IN} > 0.7 V_{CC}$	500	-	kΩ

1. Specified by design – Not tested in production.
2. Evaluated by characterization – Not tested in production.
3. The memory is selected (after a start condition).

**Table 16. Cycling performance by groups of four bytes**

Symbol	Parameter	Test condition	Max.	Unit
Ncycle	Write cycle endurance <sup>(1)</sup>	$T_A \leq 25\text{ }^\circ\text{C}$ , $V_{CC(\min)} < V_{CC} < V_{CC(\max)}$	4.000.000	Write cycle <sup>(2)</sup>
		$T_A = 85\text{ }^\circ\text{C}$ , $V_{CC(\min)} < V_{CC} < V_{CC(\max)}$	1.200.000	

1. The write cycle endurance is defined by characterization and qualification. For devices embedding the ECC functionality, the write cycle endurance is defined for a group of four bytes located at addresses  $[4*N, 4*N+1, 4*N+2, 4*N+3]$  where  $N$  is an integer.
2. A Write cycle is executed when either a page write, a byte write, a write registers, a write identification page or a lock identification page instruction is decoded. When using the byte write, the page write or the write identification page, refer also to Section 6.3: ECC (error correction code) and write cycling.

**Table 17. Memory cell data retention**

Parameter	Test condition	Min.	Unit
Data retention <sup>(1)</sup>	$T_A = 55\text{ }^\circ\text{C}$	200	Year

1. The data retention behavior is checked in production, while the data retention limit defined in this table is extracted from the characterization and qualification results.

**Table 18. DC characteristics**

Symbol	Parameter	Test conditions	Min.	Max.	Unit
$I_{LI}$	Input leakage current (SCL, SDA)	$V_{IN} = V_{SS}$ or $V_{CC}$ device in standby mode	-	$\pm 2$	$\mu\text{A}$
$I_{LO}$	Output leakage current	SDA in high-Z, external voltage applied on SDA: $V_{SS}$ or $V_{CC}$	-	$\pm 2$	$\mu\text{A}$
$I_{CC}$	Supply current (Read)	$f_C = 400\text{ kHz}$	-	0.5	mA
		$f_C = 1\text{ MHz}$	-	1	mA
$I_{CC0}$	Supply current (write)	Averaged on $T_W$ , $V_{CC} \leq 3.3\text{ V}$	-	1 <sup>(1)</sup>	mA
		Averaged on $T_W$ , $V_{CC} > 3.3\text{ V}$	-	1.5 <sup>(1)</sup>	
$I_{CC1}$	Standby supply current	Device not selected <sup>(2)</sup> $V_{IN} = V_{SS}$ or $V_{CC}$ ; $V_{CC} < 2.5\text{ V}$	-	1	$\mu\text{A}$
		Device not selected <sup>(2)</sup> $V_{IN} = V_{SS}$ or $V_{CC}$ ; $V_{CC} \geq 2.5\text{ V}$	-	2	$\mu\text{A}$
$V_{IL}$	Input low voltage (SCL, SDA, $\overline{WC}$ )	$1.6\text{ V} \leq V_{CC} < 2.5\text{ V}$	-0.45	$0.25 V_{CC}$	V
		$2.5\text{ V} \leq V_{CC} \leq 5.5\text{ V}$	-0.45	$0.30 V_{CC}$	V
$V_{IH}$	Input high voltage (SCL, SDA)	$1.6\text{ V} \leq V_{CC} < 2.5\text{ V}$	$0.75 V_{CC}$	6.5	V
		$2.5\text{ V} \leq V_{CC} \leq 5.5\text{ V}$	$0.70 V_{CC}$	6.5	V
	Input high voltage ( $\overline{WC}$ )	$1.6\text{ V} \leq V_{CC} < 2.5\text{ V}$	$0.75 V_{CC}$	$V_{CC}+0.6$	V
		$2.5\text{ V} \leq V_{CC} \leq 5.5\text{ V}$	$0.70 V_{CC}$	$V_{CC}+0.6$	V
$V_{OL}$	Output low	$I_{OL} = 1\text{ mA}$ , $V_{CC} = 1.6\text{ V}$	-	0.2	V
		$I_{OL} = 2.1\text{ mA}$ , $V_{CC} = 2.5\text{ V}$ or	-	0.4	V
		$I_{OL} = 3\text{ mA}$ , $V_{CC} = 5.5\text{ V}$			

1. Evaluated by characterization - Not tested in production.
2. The device is not selected after power-up, after a read instruction (after the stop condition), or after the completion of the internal write cycle  $t_W$  ( $t_W$  is triggered by the correct decoding of a Write instruction).

**Table 19. AC characteristics in Fast-mode**

Symbol	Alt.	Parameter	Min.	Max.	Unit
$f_C$	$f_{SCL}$	Clock frequency	-	400	kHz
$t_{CHCL}$	$t_{HIGH}$	Clock pulse width high	600	-	ns
$t_{CLCH}$	$t_{LOW}$	Clock pulse width low	1300	-	ns
$t_{QL1QL2}^{(1)}$	$t_F$	SDA (out) fall time	20 <sup>(2)</sup>	300	ns
$t_{XH1XH2}^{(1)}$	$t_R$	Input signal rise time	(3)	(3)	ns
$t_{XL1XL2}^{(1)}$	$t_F$	Input signal fall time	(3)	(3)	ns
$t_{DXCH}$	$t_{SU:DAT}$	Data in setup time	100	-	ns
$t_{CLDX}$	$t_{HD:DAT}$	Data in hold time	0	-	ns
$t_{CLQX}^{(4)}$	$t_{DH}$	Data out hold time	100	-	ns
$t_{CLQV}^{(5)}$	$t_{AA}$	Clock low to next data valid (access time)	-	900	ns
$t_{CHDL}$	$t_{SU:STA}$	Start condition setup time	600	-	ns
$t_{DLCL}$	$t_{HD:STA}$	Start condition hold time	600	-	ns
$t_{CHDH}$	$t_{SU:STO}$	Stop condition set up time	600	-	ns
$t_{DHDL}$	$t_{BUF}$	Time between Stop condition and next Start condition	1300	-	ns
$t_{WLDL}^{(1)(6)}$	$t_{SU:WC}$	$\overline{WC}$ set up time (before the start condition)	0	-	$\mu$ s
$t_{DHWH}^{(1)(7)}$	$t_{HD:WC}$	$\overline{WC}$ hold time (after the stop condition)	1	-	$\mu$ s
$t_W$	$t_{WR}$	Write cycle time	-	4 <sup>(8)</sup>	ms
$t_{NS}^{(1)}$	-	Pulse width ignored (input filter on SCL and SDA) - single glitch	-	50	ns
$t_{WU}^{(9)(10)}$	-	Wake-up time	-	5	$\mu$ s

1. Evaluated by characterization - Not tested in production.
2. With  $C_L = 10$  pF.
3. There is no min. or max. values for the input signal rise and fall times. It is however recommended by the I<sup>2</sup>C specification that the input signal rise and fall times be more than 20 ns and less than 300 ns when  $f_C < 400$  kHz.
4. To avoid spurious start and stop conditions, a minimum delay is placed between SCL=1 and the falling or rising edge of SDA.
5.  $t_{CLQV}$  is the time (from the falling edge of SCL) required by the SDA bus line to reach either  $0.3V_{CC}$  or  $0.7V_{CC}$ , assuming that the  $R_{bus} \times C_{bus}$  time constant is within the values specified in Figure 25.
6.  $\overline{WC} = 0$  setup time condition to enable the execution of a write command.
7.  $\overline{WC} = 0$  hold time condition to enable the execution of a write command.
8. 3 ms typical.
9. Specified by design - Not tested in production.
10. Wake-up time: Delay between the  $V_{CC(min)}$  stable and the first accepted command.

**Table 20. AC characteristics in Fast-mode Plus**

Symbol	Alt.	Parameter	Min.	Max.	Unit
$f_C$	$f_{SCL}$	Clock frequency	-	1	MHz
$t_{CHCL}$	$t_{HIGH}$	Clock pulse width high	260	-	ns
$t_{CLCH}$	$t_{LOW}$	Clock pulse width low	500	-	ns
$t_{XH1XH2}$	$t_R$	Input signal rise time	(1)	(1)	ns
$t_{XL1XL2}$	$t_F$	Input signal fall time	(1)	(1)	ns
$t_{QL1QL2}^{(2)}$	$t_F$	SDA (out) fall time	20 <sup>(3)</sup>	120	ns
$t_{DXCH}$	$t_{SU:DAT}$	Data in setup time	50	-	ns
$t_{CLDX}$	$t_{HD:DAT}$	Data in hold time	0	-	ns
$t_{CLQX}^{(4)}$	$t_{DH}$	Data out hold time	100	-	ns
$t_{CLQV}^{(5)}$	$t_{AA}$	Clock low to next data valid (access time)	-	450	ns
$t_{CHDL}$	$t_{SU:STA}$	Start condition setup time	250	-	ns
$t_{DLCL}$	$t_{HD:STA}$	Start condition hold time	250	-	ns
$t_{CHDH}$	$t_{SU:STO}$	Stop condition setup time	250	-	ns
$t_{DHDL}$	$t_{BUF}$	Time between Stop condition and next Start condition	500	-	ns
$t_{WLDL}^{(2)(6)}$	$t_{SU:WC}$	$\overline{WC}$ set up time (before the start condition)	0	-	$\mu$ s
$t_{DHWL}^{(2)(7)}$	$t_{HD:WC}$	$\overline{WC}$ hold time (after the stop condition)	1	-	$\mu$ s
$t_W$	$t_{WR}$	Write cycle time	-	4 <sup>(8)</sup>	ms
$t_{NS}^{(2)}$	-	Pulse width ignored (input filter on SCL and SDA)	-	50	ns
$t_{WU}^{(9)(10)}$	-	Wake-up time	-	5	$\mu$ s

1. There is no min. or max. values for the input signal rise and fall times. It is however recommended by the I<sup>2</sup>C specification that the input signal rise and fall times be less than 120 ns when  $f_C < 1$  MHz.
2. Evaluated by characterization - Not tested in production.
3. With  $CL = 10$  pF.
4. To avoid spurious Start and Stop conditions, a minimum delay is placed between  $SCL=1$  and the falling or rising edge of SDA.
5.  $t_{CLQV}$  is the time (from the falling edge of SCL) required by the SDA bus line to reach either  $0.3 V_{CC}$  or  $0.7 V_{CC}$ , assuming that the  $R_{bus} \times C_{bus}$  time constant is within the values specified in Figure 26.
6.  $\overline{WC} = 0$  setup time condition to enable the execution of a write command.
7.  $\overline{WC} = 0$  hold time condition to enable the execution of a write command.
8. 3 ms typical.
9. Specified by design - Not tested in production.
10. Wake-up time: Delay between the  $V_{CC(min)}$  stable and the first accepted commands.

**Figure 25. Maximum  $R_{bus}$  value versus bus parasitic capacitance ( $C_{bus}$ ) for an I<sup>2</sup>C<sub>bus</sub> at maximum frequency  $f_c = 400$  kHz**

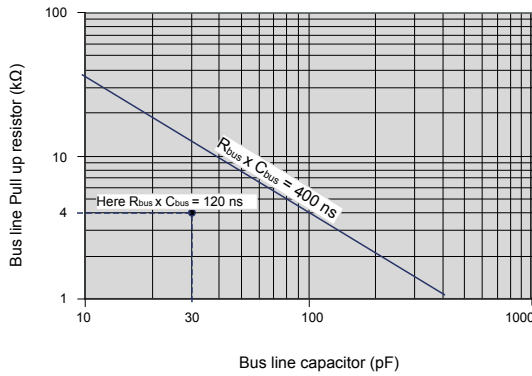

The  $R_{bus} \times C_{bus}$  time constant must be below the 400 ns time constant line displayed on the left

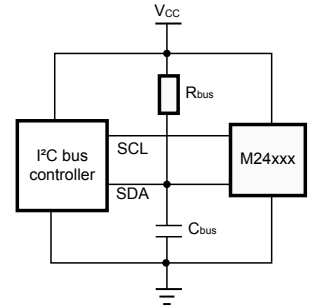

DT137916V5

**Figure 26. Maximum  $R_{bus}$  value versus bus parasitic capacitance ( $C_{bus}$ ) for an I<sup>2</sup>C bus at maximum frequency  $f_c = 1$  MHz**

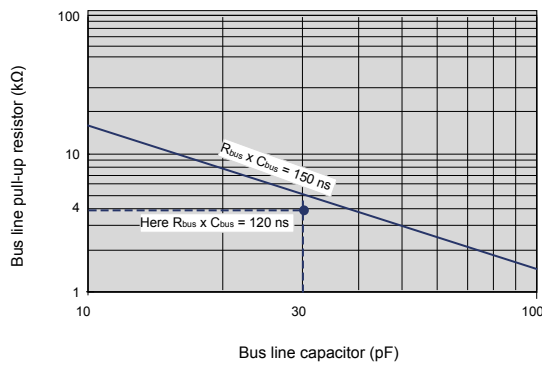

The  $R_{bus} \times C_{bus}$  time constant must be below the 150 ns time constant line displayed on the left

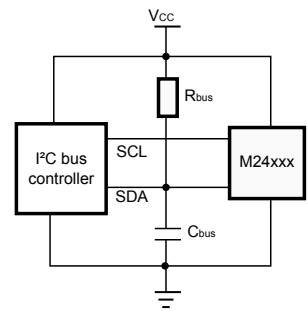

DT19745V8



## 10 Package information

To meet environmental requirements, ST offers these devices in different grades of ECOPACK packages, depending on their level of environmental compliance. ECOPACK specifications, grade definitions, and product status are available at: [www.st.com](http://www.st.com).

ECOPACK is an ST trademark.

For die information concerning the M24M01E-F delivered in unsawn wafer, contact your nearest ST Sales office.

### 10.1 UFDFPN8 (DFN8) package information

This UFDFPN is an 8-lead, 2 x 3 mm, 0.5 mm pitch ultra thin profile fine pitch dual flat package.

Figure 28. UFDFPN8 - Outline

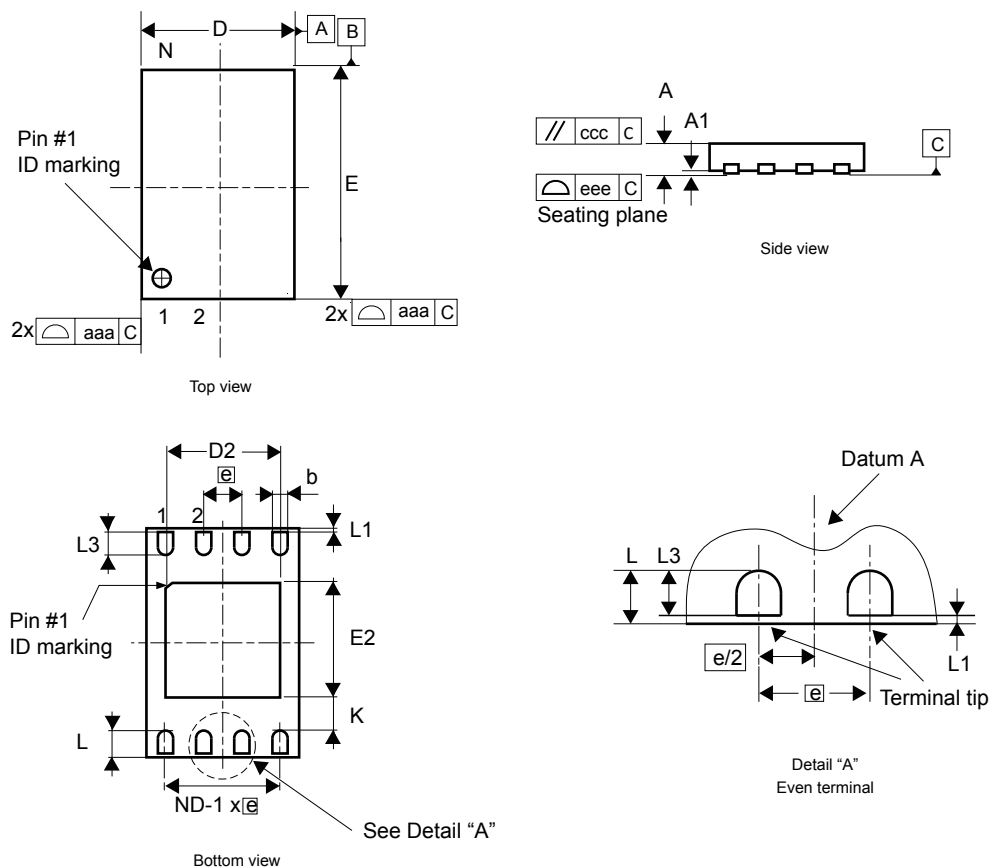

1. The maximum package warpage is 0.05 mm.
2. Exposed copper is not systematic and can appear partially or totally according to the cross section.
3. Drawing is not to scale.
4. The central pad (the area E2 by D2 in the above illustration) must be either connected to  $V_{SS}$  or left floating (not connected) in the end application.

**Table 21. UFDFPN8 - Mechanical data**

Symbol	millimeters			inches <sup>(1)</sup>		
	Min	Typ	Max	Min	Typ	Max
A	0.450	0.550	0.600	0.0177	0.0217	0.0236
A1	0.000	0.020	0.050	0.0000	0.0008	0.0020
b <sup>(2)</sup>	0.200	0.250	0.300	0.0079	0.0098	0.0118
D	1.900	2.000	2.100	0.0748	0.0787	0.0827
D2	1.200	-	1.600	0.0472	-	0.0630
E	2.900	3.000	3.100	0.1142	0.1181	0.1220
E2	1.200	-	1.600	0.0472	-	0.0630
e	-	0.500	-	-	0.0197	-
K	0.300	-	-	0.0118	-	-
L	0.300	-	0.500	0.0118	-	0.0197
L1	-	-	0.150	-	-	0.0059
L3	0.300	-	-	0.0118	-	-
aaa	-	-	0.150	-	-	0.0059
bbb	-	-	0.100	-	-	0.0039
ccc	-	-	0.100	-	-	0.0039
ddd	-	-	0.050	-	-	0.0020
eee <sup>(3)</sup>	-	-	0.080	-	-	0.0031

1. Values in inches are converted from mm and rounded to four decimal digits.
2. Dimension b applies to the plated terminal and is measured between 0.15 and 0.30 mm from the terminal tip.
3. Applied for exposed die paddle and terminals. Exclude embedding part of the exposed die paddle from measuring.

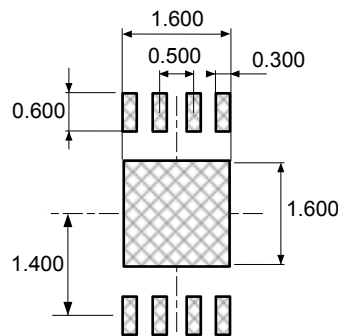
**Figure 29. UFDFPN8 - Footprint example**

1. Dimensions are expressed in millimeters.

ZWb\_UFDFPN8\_FP\_V2

## 10.2 TSSOP8 package information

This TSSOP8 is an 8-lead, 3 x 6.4 mm, 0.65 mm pitch, thin shrink small outline package.

Figure 30. TSSOP8 – Outline

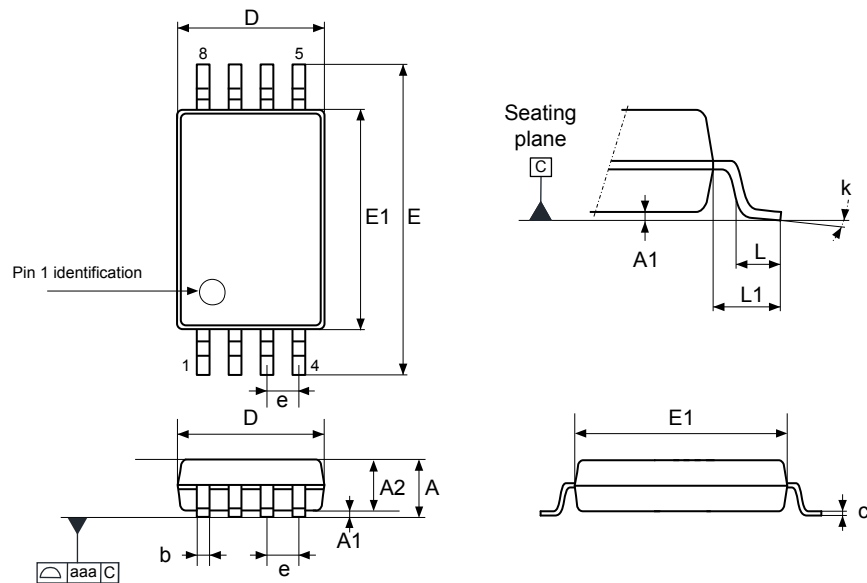

DT\_6P\_A\_TSSOP8\_ME\_V4

1. Drawing is not to scale.

Table 22. TSSOP8 - Mechanical data

Symbol	millimeters			inches <sup>(1)</sup>		
	Min.	Typ.	Max.	Min.	Typ.	Max.
A	-	-	1.200	-	-	0.0472
A1	0.050	-	0.150	0.0020	-	0.0059
A2	0.800	1.000	1.050	0.0315	0.0394	0.0413
b	0.190	-	0.300	0.0075	-	0.0118
c	0.090	-	0.200	0.0035	-	0.0079
D <sup>(2)</sup>	2.900	3.000	3.100	0.1142	0.1181	0.1220
e	-	0.650	-	-	0.0256	-
E	6.200	6.400	6.600	0.2441	0.2520	0.2598
E1 <sup>(3)</sup>	4.300	4.400	4.500	0.1693	0.1732	0.1772
L	0.450	0.600	0.750	0.0177	0.0236	0.0295
L1	-	1.000	-	-	0.0394	-
k	0°	-	8°	0°	-	8°
aaa	-	-	0.100	-	-	0.0039

1. Values in inches are converted from mm and rounded to four decimal digits.
2. Dimension D does not include mold flash, protrusions, or gate burrs. Mold flash, protrusions, or gate burrs shall not exceed 0.15 mm per side.
3. Dimension E1 does not include interlead flash or protrusions. Interlead flash or protrusions shall not exceed 0.25 mm per side.

Note: The package top may be smaller than the package bottom. Dimensions D and E1 are determined at the outermost extremes of the plastic body exclusive of the mold flash, tie bar burrs, gate burrs, and interleads flash, but including any mismatch between the top and bottom of the plastic body. The measurement side for the mold flash, protrusions, or gate burrs is the bottom side.

Figure 31. TSSOP8 – Footprint example

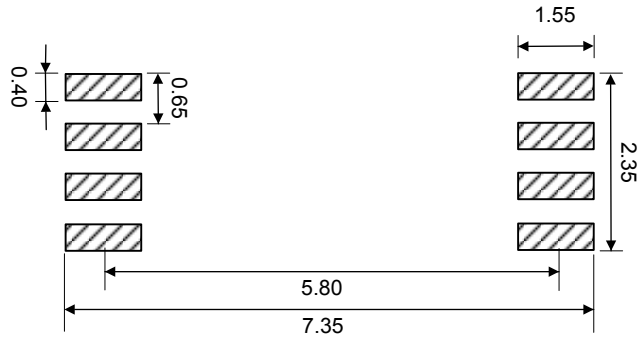

DT\_6P\_TSSOP8\_FP\_V2

1. Dimensions are expressed in millimeters.

## 10.3 SO8N package information

This SO8N is an 8-lead, 4.9 x 6 mm, plastic small outline, 150 mils body width, package.

**Figure 32. SO8N - Outline**

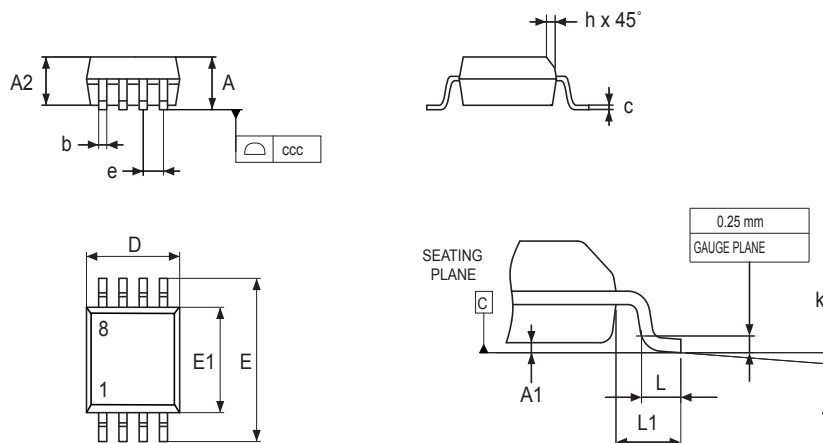

07\_SO8\_ME\_V2

1. Drawing is not to scale.

**Table 23. SO8N - Mechanical data**

Symbol	millimeters			inches <sup>(1)</sup>		
	Min.	Typ.	Max.	Min.	Typ.	Max.
A	-	-	1.750	-	-	0.0689
A1	0.100	-	0.250	0.0039	-	0.0098
A2	1.250	-	-	0.0492	-	-
b	0.280	-	0.480	0.0110	-	0.0189
c	0.170	-	0.230	0.0067	-	0.0091
D <sup>(2)</sup>	4.800	4.900	5.000	0.1890	0.1929	0.1969
E	5.800	6.000	6.200	0.2283	0.2362	0.2441
E1 <sup>(3)</sup>	3.800	3.900	4.000	0.1496	0.1535	0.1575
e	-	1.270	-	-	0.0500	-
h	0.250	-	0.500	0.0098	-	0.0197
k	0°	-	8°	0°	-	8°
L	0.400	-	1.270	0.0157	-	0.0500
L1	-	1.040	-	-	0.0409	-
ccc	-	-	0.100	-	-	0.0039

1. Values in inches are converted from mm and rounded to four decimal digits.
2. Dimension D does not include mold flash, protrusions, or gate burrs. Mold flash, protrusions, or gate burrs shall not exceed 0.15 mm per side.
3. Dimension E1 does not include interlead flash or protrusions. Interlead flash or protrusions shall not exceed 0.25 mm per side.

**Note:** The package top may be smaller than the package bottom. Dimensions D and E1 are determined at the outermost extremes of the plastic body exclusive of mold flash, tie bar burrs, gate burrs, and interleads flash, but including any mismatch between the top and bottom of the plastic body. The measurement side for mold flash, protrusions, or gate burrs is the bottom side.

Figure 33. SO8N - Footprint example

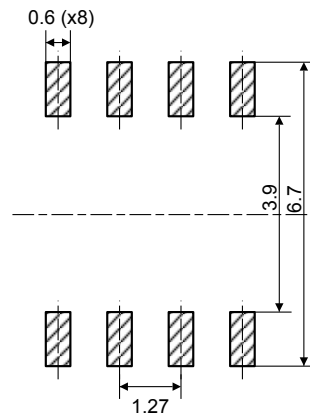

07\_SO8N\_FP\_V2

1. Dimensions are expressed in millimeters.

## 10.4 WLCSP5 (CS) package information

This WLCSP5 is a 5-ball, 1.024 x 1.626 mm, 0.800 mm pitch, wafer level chip scale package.

Figure 34. WLCSP5 (CS) - Outline

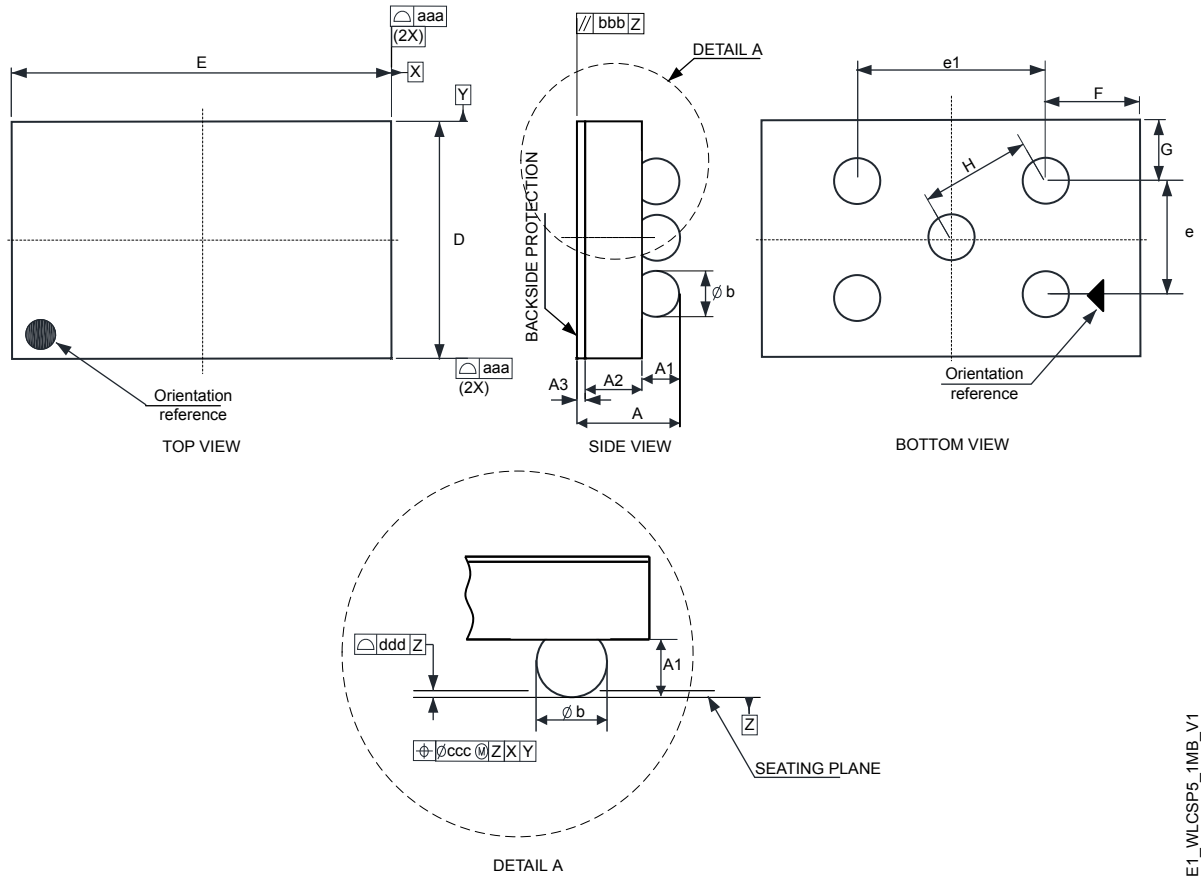

E1\_WLCSP5\_1MB\_V1

1. Drawing is not to scale.
2. Bump position designation per JESD 95-1, SPP-010.

**Table 24. WLCSP5 (CS) - Mechanical data**

Symbol	millimeters			inches <sup>(1)</sup>		
	Min	Typ	Max	Min	Typ	Max
A <sup>(2)</sup>	0.490	0.520	0.550	0.0193	0.0205	0.0217
A1	0.150	0.165	0.180	0.0059	0.0065	0.0071
A2	0.305	0.330	0.355	0.0120	0.0130	0.0140
A3	-	0.025	-	-	0.0010	-
∅ b <sup>(3)(4)</sup>	0.190	0.210	0.230	0.0075	0.0083	0.0091
D	1.004	1.024	1.044	0.0395	0.0403	0.0411
E	1.606	1.626	1.646	0.0632	0.0640	0.0648
e	-	0.500	-	-	0.0197	-
e1	-	0.800	-	-	0.0315	-
F	-	0.413	-	-	0.0163	-
G	-	0.262	-	-	0.0103	-
H	-	0.472	-	-	0.0186	-
aaa	-	-	0.110	-	-	0.0008
bbb	-	-	0.110	-	-	0.0024
ccc	-	-	0.110	-	-	0.0006
ddd	-	-	0.060	-	-	0.0016

1. Values in inches are converted from mm and rounded to four decimal digits.
2. A1, A2, and A3 have their own specification. The sum of all of them must comply with the A min and max spec.
3. Dimension is measured at the maximum bump diameter parallel to primary datum Z.
4. Primary datum Z and seating plane are defined by the spherical crowns of the bump.

## 10.5 WLCSP5 (CP) package information

This WLCSP5 is a 5-ball, 1.628 x 1.026 mm, 0.800 mm pitch, wafer level chip scale package.

Figure 35. WLCSP5 (CP) - Outline

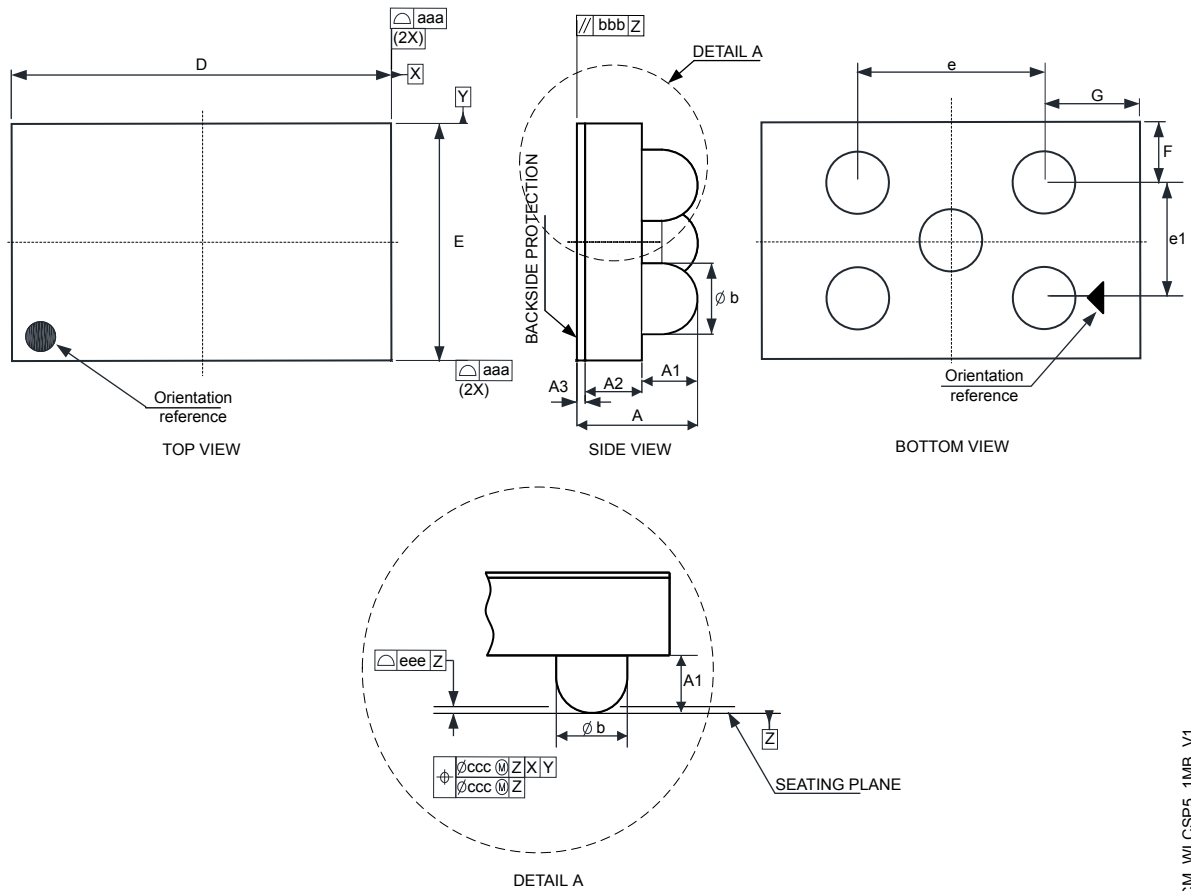

CM\_WLCSP5\_1MB\_V1

1. Drawing is not to scale.
2. Bump position designation per JESD 95-1, SPP-010.

**Table 25. WLCSP5 (CP) - Mechanical data**

Symbol	millimeters			inches <sup>(1)</sup>		
	Min	Typ	Max	Min	Typ	Max
A <sup>(2)</sup>	0.225	0.255	0.285	0.0090	0.0100	0.0110
A1	-	0.055	0.065	0.0019	0.0022	0.0025
A2	-	0.175	0.190	0.0064	0.0069	0.0074
A3	-	0.025	-	0.0008	0.0010	0.0012
∅ b <sup>(3)(4)</sup>	0.190	0.210	0.230	0.0075	0.0083	0.0091
D	1.603	1.628	1.653	0.0631	0.0641	0.0651
E	1.001	1.026	1.051	0.0394	0.0404	0.0414
e	-	0.800	-	-	0.0315	-
e1	-	0.500	-	-	0.0197	-
F	-	0.263	-	-	0.0104	-
G	-	0.414	-	-	0.0163	-
aaa	-	-	0.110	-	-	0.0043
bbb	-	-	0.110	-	-	0.0043
ccc	-	-	0.110	-	-	0.0043
ddd	-	-	0.060	-	-	0.0024
eee	-	-	0.060	-	-	0.0024

1. Values in inches are converted from mm and rounded to four decimal digits.
2. A1, A2, and A3 have their own specification. The sum of all of them must comply with the A min and max spec.
3. Dimension is measured at the maximum bump diameter parallel to primary datum Z.
4. Primary datum Z and seating plane are defined by the spherical crowns of the bump.

## 11 Ordering information

Table 26. Ordering information scheme

Example:	M24	M01E	-	F	MN	6	T	P	F
<b>Device type</b>									
M24 = I <sup>2</sup> C serial access EEPROM									
<b>Device function</b>									
M01E = 1 Mbit (128 K x 8 bit)									
<b>Operating voltage</b>									
F = V <sub>CC</sub> = 1.6 V to 5.5 V									
<b>Package<sup>(1)</sup></b>									
MN = SO8 (150 mil width)									
DW = TSSOP8 (169 mil width)									
MC = UDFPN8 (DFN8)									
CS = WLCSP 5 ball									
CP = Thin WLCSP 5 ball									
<b>Device grade</b>									
6 = Industrial device tested with standard test flow over -40 to 85 °C									
<b>Option</b>									
T = Tape and reel packing									
Blank = Tube packing									
<b>Plating technology and device address<sup>(2)</sup> or process<sup>(3)</sup></b>									
P or G = ECOPACK2 and device address 00									
1 to 3 = ECOPACK2 and preprogrammed device address									
/V = Manufacturing technology code <sup>(3)</sup>									
<b>Option</b>									
Blank = No back side coating									
F = Back side coating									

1. ECOPACK2 (RoHS compliant and free of brominated, chlorinated, and antimony oxide flame retardants).
2. See Table 6.
3. For WLCSP only.

**Note:** For a list of available options (memory, package, and so on) or for further information on any aspect of this device, contact your nearest ST sales office.

**Note:** Parts marked as “ES” or “E” are not yet qualified and therefore not approved for use in production. ST is not responsible for any consequences resulting from such use. In no event will ST be liable for the customer using any of these engineering samples in production. ST’s Quality department must be contacted prior to any decision to use these engineering samples to run a qualification activity.

## Revision history

**Table 27. Document revision history**

Date	Revision	Changes
26-May-2023	1	Initial release.
11-Dec-2023	2	Updated: <ul style="list-style-type: none"> <li>• Features</li> <li>• Section 1: Description</li> <li>• Section 5.5: Device addressing</li> <li>• Section 10.4: WLCSP5 (CS) package information</li> <li>• Section 10.5: WLCSP5 (CP) package information</li> <li>• Section 11: Ordering information</li> </ul>
05-Aug-2024	3	Updated: <ul style="list-style-type: none"> <li>• Section 1: Description</li> <li>• Section 6.5.1: Read operation on DTI register</li> <li>• Section 6.5.2: Read operation on CDA register</li> <li>• Section 6.5.3: Read operation on SWP register</li> <li>• Section 6.5.4: Read operation on identification page</li> <li>• Section 10.5: WLCSP5 (CP) package information</li> <li>• Section 11: Ordering information</li> </ul>

## Contents

<b>1</b>	<b>Description</b> .....	<b>2</b>
<b>2</b>	<b>Signal description</b> .....	<b>4</b>
2.1	Serial clock (SCL) .....	4
2.2	Serial data (SDA) .....	4
2.3	Write control ( $\overline{WC}$ ) .....	4
2.4	V <sub>SS</sub> (ground) .....	4
2.5	Supply voltage (V <sub>CC</sub> ) .....	5
2.5.1	Operating supply voltage (V <sub>CC</sub> ) .....	5
2.5.2	Power-up conditions .....	5
2.5.3	Device reset .....	5
2.5.4	Power-down conditions .....	5
<b>3</b>	<b>Memory organization</b> .....	<b>6</b>
<b>4</b>	<b>Device features</b> .....	<b>7</b>
4.1	Device type identifier register (DTI) .....	7
4.2	Configurable device address register (CDA) .....	8
4.3	Software write protection register (SWP) .....	9
4.4	Identification page .....	10
<b>5</b>	<b>Device operation</b> .....	<b>11</b>
5.1	Start condition .....	12
5.2	Stop condition .....	12
5.3	Data input .....	12
5.4	Acknowledge bit (ACK) .....	12
5.5	Device addressing .....	13
<b>6</b>	<b>Instructions</b> .....	<b>15</b>
6.1	Write operations on memory array .....	15
6.1.1	Byte write .....	16
6.1.2	Page write .....	17
6.2	Write operations on features .....	18
6.2.1	Write operation on DTI register .....	18
6.2.2	Write operation on CDA register .....	18
6.2.3	Write operation on SWP register .....	19
6.2.4	Write operation on identification page .....	20
6.2.5	Lock operation on identification page .....	22
6.2.6	Minimizing write delays by polling on ACK .....	23

6.3	ECC (error correction code) and write cycling .....	24
6.4	Read operations on memory array .....	25
6.4.1	Random address read .....	26
6.4.2	Current address read .....	26
6.4.3	Sequential read .....	26
6.5	Read operations on features .....	27
6.5.1	Read operation on DTI register .....	27
6.5.2	Read operation on CDA register .....	28
6.5.3	Read operation on SWP register .....	29
6.5.4	Read operation on identification page .....	30
6.5.5	Read lock status on identification page .....	31
<b>7</b>	<b>Initial delivery state .....</b>	<b>32</b>
<b>8</b>	<b>Maximum ratings .....</b>	<b>33</b>
<b>9</b>	<b>DC and AC parameters .....</b>	<b>34</b>
<b>10</b>	<b>Package information .....</b>	<b>40</b>
10.1	UFD8FN8 (DFN8) package information .....	40
10.2	TSSOP8 package information .....	42
10.3	SO8N package information .....	44
10.4	WLCSP5 (CS) package information .....	46
10.5	WLCSP5 (CP) package information .....	48
<b>11</b>	<b>Ordering information .....</b>	<b>50</b>
	<b>Revision history .....</b>	<b>51</b>

## List of tables

<b>Table 1.</b>	Signal names . . . . .	2
<b>Table 2.</b>	Device type identifier register. . . . .	7
<b>Table 3.</b>	Device type identifier register description . . . . .	7
<b>Table 4.</b>	Configurable device address register . . . . .	8
<b>Table 5.</b>	Configurable device address register description . . . . .	8
<b>Table 6.</b>	Preprogrammed device address . . . . .	9
<b>Table 7.</b>	Software write protection register values . . . . .	9
<b>Table 8.</b>	Software write protection register description. . . . .	10
<b>Table 9.</b>	Device select code. . . . .	13
<b>Table 10.</b>	First byte address . . . . .	13
<b>Table 11.</b>	Second byte address . . . . .	14
<b>Table 12.</b>	Absolute maximum ratings . . . . .	33
<b>Table 13.</b>	Operating conditions . . . . .	34
<b>Table 14.</b>	AC measurement conditions . . . . .	34
<b>Table 15.</b>	Input parameters . . . . .	34
<b>Table 16.</b>	Cycling performance by groups of four bytes . . . . .	35
<b>Table 17.</b>	Memory cell data retention . . . . .	35
<b>Table 18.</b>	DC characteristics . . . . .	35
<b>Table 19.</b>	AC characteristics in Fast-mode. . . . .	36
<b>Table 20.</b>	AC characteristics in Fast-mode Plus . . . . .	37
<b>Table 21.</b>	UFDFPN8 - Mechanical data . . . . .	41
<b>Table 22.</b>	TSSOP8 - Mechanical data . . . . .	42
<b>Table 23.</b>	SO8N - Mechanical data . . . . .	44
<b>Table 24.</b>	WLCSP5 (CS) - Mechanical data . . . . .	47
<b>Table 25.</b>	WLCSP5 (CP) - Mechanical data . . . . .	49
<b>Table 26.</b>	Ordering information scheme. . . . .	50
<b>Table 27.</b>	Document revision history . . . . .	51

## List of figures

<b>Figure 1.</b>	Logic diagram . . . . .	2
<b>Figure 2.</b>	8-pin package connections, top view . . . . .	2
<b>Figure 3.</b>	5-ball package connection . . . . .	3
<b>Figure 4.</b>	Block diagram . . . . .	6
<b>Figure 5.</b>	I <sup>2</sup> C bus protocol . . . . .	11
<b>Figure 6.</b>	Write mode sequences without write protection (data write enabled) . . . . .	16
<b>Figure 7.</b>	Write mode sequences with write protection (data write inhibited) . . . . .	17
<b>Figure 8.</b>	Write CDA register (data write enabled) . . . . .	18
<b>Figure 9.</b>	Write CDA register (data write inhibited by software or hardware) . . . . .	18
<b>Figure 10.</b>	Write SWP register (data write enabled) . . . . .	19
<b>Figure 11.</b>	Write SWP register (data write inhibited by software or hardware) . . . . .	19
<b>Figure 12.</b>	Write identification page (page unlocked) . . . . .	20
<b>Figure 13.</b>	Write identification page (page locked or hard protected) . . . . .	21
<b>Figure 14.</b>	Lock operation on identification page (unlocked or data write enabled) . . . . .	22
<b>Figure 15.</b>	Lock operation on identification page (already locked or data write inhibited by hardware) . . . . .	22
<b>Figure 16.</b>	Write cycle polling flowchart using ACK . . . . .	23
<b>Figure 17.</b>	Read mode sequences . . . . .	25
<b>Figure 18.</b>	Random read DTI register . . . . .	27
<b>Figure 19.</b>	Random read CDA register . . . . .	28
<b>Figure 20.</b>	Random read SWP register . . . . .	29
<b>Figure 21.</b>	Random read identification page . . . . .	30
<b>Figure 22.</b>	Read lock status (identification page unlocked) . . . . .	31
<b>Figure 23.</b>	Read lock status (identification page locked) . . . . .	31
<b>Figure 24.</b>	AC measurement I/O waveform . . . . .	34
<b>Figure 25.</b>	Maximum R <sub>bus</sub> value versus bus parasitic capacitance (C <sub>bus</sub> ) for an I <sup>2</sup> C <sub>bus</sub> at maximum frequency f <sub>C</sub> = 400 kHz	38
<b>Figure 26.</b>	Maximum R <sub>bus</sub> value versus bus parasitic capacitance (C <sub>bus</sub> ) for an I <sup>2</sup> C bus at maximum frequency f <sub>C</sub> = 1 MHz	38
<b>Figure 27.</b>	AC waveforms . . . . .	39
<b>Figure 28.</b>	UFDFPN8 - Outline . . . . .	40
<b>Figure 29.</b>	UFDFPN8 - Footprint example . . . . .	41
<b>Figure 30.</b>	TSSOP8 – Outline . . . . .	42
<b>Figure 31.</b>	TSSOP8 – Footprint example . . . . .	43
<b>Figure 32.</b>	SO8N - Outline . . . . .	44
<b>Figure 33.</b>	SO8N - Footprint example . . . . .	45
<b>Figure 34.</b>	WLCSP5 (CS) - Outline . . . . .	46
<b>Figure 35.</b>	WLCSP5 (CP) - Outline . . . . .	48

**IMPORTANT NOTICE – READ CAREFULLY**

STMicroelectronics NV and its subsidiaries (“ST”) reserve the right to make changes, corrections, enhancements, modifications, and improvements to ST products and/or to this document at any time without notice. Purchasers should obtain the latest relevant information on ST products before placing orders. ST products are sold pursuant to ST’s terms and conditions of sale in place at the time of order acknowledgment.

Purchasers are solely responsible for the choice, selection, and use of ST products and ST assumes no liability for application assistance or the design of purchasers’ products.

No license, express or implied, to any intellectual property right is granted by ST herein.

Resale of ST products with provisions different from the information set forth herein shall void any warranty granted by ST for such product.

ST and the ST logo are trademarks of ST. For additional information about ST trademarks, refer to [www.st.com/trademarks](http://www.st.com/trademarks). All other product or service names are the property of their respective owners.

Information in this document supersedes and replaces information previously supplied in any prior versions of this document.

© 2024 STMicroelectronics – All rights reserved